



US008399880B2

(12) **United States Patent**  
**Kim et al.**

(10) **Patent No.:** **US 8,399,880 B2**  
(45) **Date of Patent:** **\*Mar. 19, 2013**

(54) **HETEROARYLAMINE COMPOUND AND ORGANIC LIGHT-EMITTING DEVICE INCLUDING THE SAME**

(75) Inventors: **Young-Kook Kim**, Yongin (KR);  
**Seok-Hwan Hwang**, Yongin (KR);  
**Yoon-Hyun Kwak**, Yongin (KR);  
**Hye-Jin Jung**, Yongin (KR); **Jong-Hyuk Lee**, Yongin (KR); **Jin-O Lim**, Yongin (KR); **Chang-Ho Lee**, Yongin (KR)

(73) Assignee: **Samsung Display Co., Ltd.**, Yongin-si (KR)

(\*) Notice: Subject to any disclaimer, the term of this patent is extended or adjusted under 35 U.S.C. 154(b) by 194 days.

This patent is subject to a terminal disclaimer.

(21) Appl. No.: **12/869,596**

(22) Filed: **Aug. 26, 2010**

(65) **Prior Publication Data**

US 2011/0049494 A1 Mar. 3, 2011

(30) **Foreign Application Priority Data**

Aug. 28, 2009 (KR) ..... 10-2009-0080703

(51) **Int. Cl.**

**H01L 51/54** (2006.01)

**C07D 209/58** (2006.01)

**C07D 209/88** (2006.01)

(52) **U.S. Cl.** ..... **257/40; 428/690; 548/427; 548/442; 257/E51.05**

(58) **Field of Classification Search** ..... None  
See application file for complete search history.

(56) **References Cited**

U.S. PATENT DOCUMENTS

6,280,859 B1 8/2001 Onikubo et al.  
6,465,115 B2 10/2002 Shi et al.  
6,596,415 B2 7/2003 Shi et al.

(Continued)

FOREIGN PATENT DOCUMENTS

JP 10251633 9/1998  
JP 10310574 A 11/1998

(Continued)

OTHER PUBLICATIONS

KIPO Registration Determination Certificate dated Mar. 2, 2012, for Korean Patent application 10-2009-0080702, (5 pages).

*Primary Examiner* — Jennifer Chriss

*Assistant Examiner* — J. L. Yang

(74) *Attorney, Agent, or Firm* — Christie, Parker & Hale, LLP

(57) **ABSTRACT**

Embodiments of the present invention are directed to heteroarylamine compounds represented by Formula 1, and organic light-emitting devices including the heteroarylamine compounds. The organic light-emitting devices using the heteroarylamine compounds have high-efficiency, low driving voltages, high luminance and long lifespans.

Formula 1

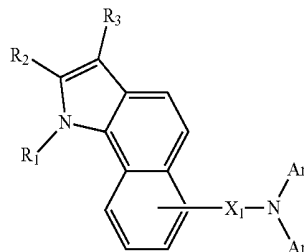

**18 Claims, 1 Drawing Sheet**

SECOND ELECTRODE
EIL
ETL
EML
HTL
HIL
FIRST ELECTRODE

# US 8,399,880 B2

Page 2

---

## U.S. PATENT DOCUMENTS

2007/0278938 A1 12/2007 Yabunouchi et al.  
2010/0045170 A1 2/2010 Lee et al.  
2011/0049487 A1\* 3/2011 Kim et al. .... 257/40

## FOREIGN PATENT DOCUMENTS

JP 2002148835 A 5/2002

JP 2005093159 A 4/2005  
JP 2008133225 A 6/2008  
KR 20080112325 A 12/2008  
KR 10-2009-0024431 3/2009  
KR 10-0910150 B1 8/2009  
WO WO 2009/031807 A2 3/2009

\* cited by examiner

FIG. 1

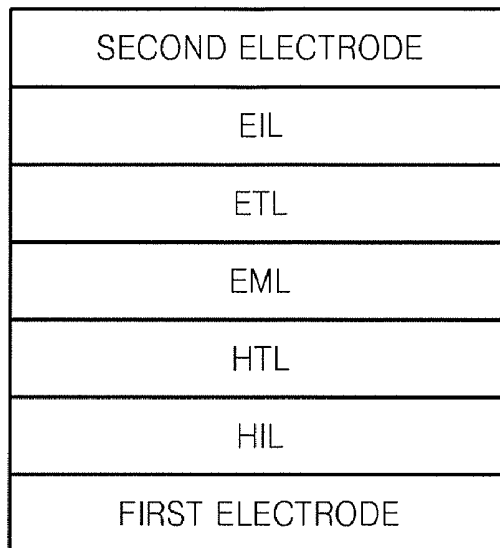
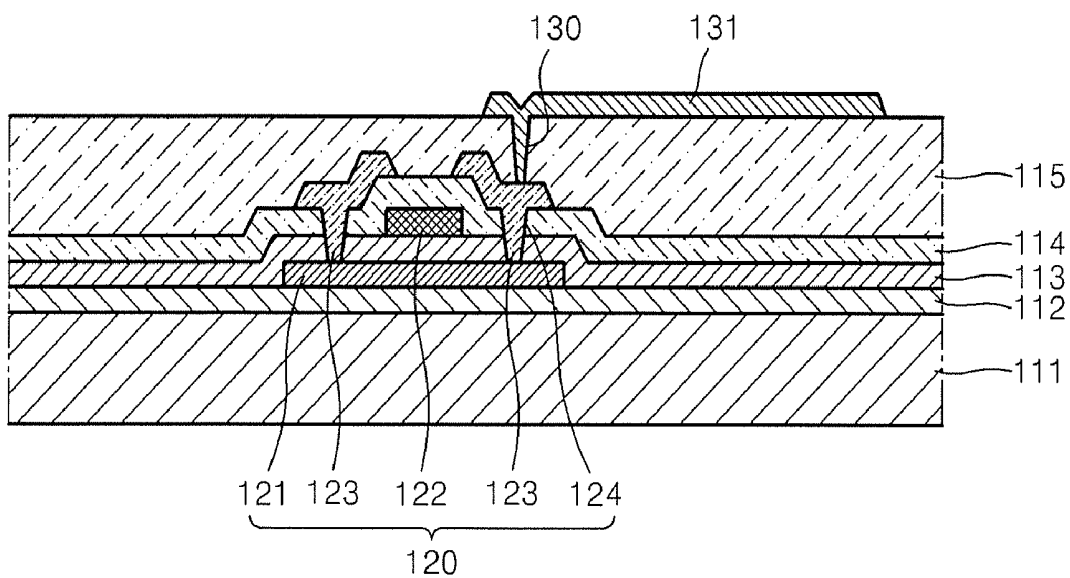

FIG. 2



1

# HETEROARYLAMINE COMPOUND AND ORGANIC LIGHT-EMITTING DEVICE INCLUDING THE SAME

## CROSS-REFERENCE TO RELATED PATENT APPLICATION

This application claims priority to and the benefit of Korean Patent Application No. 10-2009-0080703, filed on Aug. 28, 2009 in the Korean Intellectual Property Office, the entire content of which is incorporated herein by reference.

## BACKGROUND OF THE INVENTION

### 1. Field of the Invention

The present invention relates to heteroarylamine compounds and to organic light-emitting devices including the heteroarylamine compounds.

### 2. Description of the Related Art

Light-emitting devices are self-emission type display devices having wide viewing angles, high contrast ratios, and short response times. Due to these characteristics, light-emitting devices are drawing more attention. Such light-emitting devices can be roughly classified into inorganic light-emitting devices (which include emission layers containing inorganic compound), and organic light-emitting devices (which include emission layers containing organic compounds). Specifically, organic light-emitting devices have higher luminance, lower driving voltages, and shorter response times than inorganic light-emitting devices, and can produce multi-colored displays. Thus, much research into organic light-emitting devices has been conducted.

Typically, an organic light-emitting device has a stacked structure including an anode, a cathode and an organic emission layer between the anode and cathode. However, a hole injection layer and/or a hole transport layer may be further stacked between the anode and the organic emission layer, and/or an electron transport layer may be further stacked between the organic emission layer and the cathode. In other words, an organic light-emitting device may have an anode/hole transport layer/organic emission layer/cathode stack structure or an anode/hole transport layer/organic emission layer/electron transport layer/cathode stack structure.

Known materials for the hole injection layer and/or hole transport layer of organic light-emitting devices do not have satisfactory lifespan, efficiency, and power consumption characteristics, thus leaving much room for improvement.

## SUMMARY OF THE INVENTION

According to embodiments of the present invention, an organic layer material has improved electrical stability and charge transporting capability, high glass transition temperature, and improved ability to prevent crystallization. The organic layer material is suitable for fluorescent or phosphorescent organic light-emitting devices (OLEDs), including full-color OLEDs (which can generate all colors, including red, green, blue, and white).

In some embodiments of the present invention, an OLED includes an organic layer formed of the above-described material. The OLED has high efficiency, low driving voltage, and improved luminance. In other embodiments, a flat panel display device includes the OLED.

2

According to embodiments of the present invention, a heteroarylamine compound is represented by Formula 1 below:

Formula 1

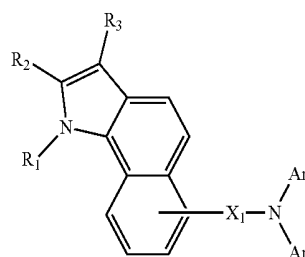

In Formula 1, each of Ar<sub>1</sub> and Ar<sub>2</sub> is independently selected from substituted and unsubstituted C<sub>6</sub>-C<sub>60</sub> aryl groups, substituted and unsubstituted C<sub>4</sub>-C<sub>60</sub> heteroaryl groups, and substituted and unsubstituted C<sub>6</sub>-C<sub>60</sub> condensed polycyclic groups. X<sub>1</sub> is selected from substituted and unsubstituted C<sub>6</sub>-C<sub>30</sub> arylene groups, substituted and unsubstituted C<sub>4</sub>-C<sub>30</sub> heteroarylene groups, and substituted and unsubstituted C<sub>6</sub>-C<sub>30</sub> condensed polycyclic groups. Each of R<sub>1</sub>, R<sub>2</sub> and R<sub>3</sub> is independently selected from hydrogen, heavy hydrogen, substituted and unsubstituted C<sub>1</sub>-C<sub>50</sub> alkyl groups, substituted and unsubstituted C<sub>1</sub>-C<sub>50</sub> alkoxy groups, substituted and unsubstituted C<sub>1</sub>-C<sub>50</sub> alkoxy carbonyl groups, substituted and unsubstituted C<sub>6</sub>-C<sub>60</sub> aryl groups, substituted and unsubstituted C<sub>5</sub>-C<sub>50</sub> aryloxy groups, substituted and unsubstituted C<sub>5</sub>-C<sub>50</sub> arylthio groups, —N(R)(R') groups (wherein each of R and R' is independently selected from substituted and unsubstituted C<sub>1</sub>-C<sub>50</sub> alkyl groups and substituted and unsubstituted C<sub>6</sub>-C<sub>50</sub> aryl groups), substituted and unsubstituted C<sub>3</sub>-C<sub>50</sub> carbocyclic groups, substituted and unsubstituted C<sub>4</sub>-C<sub>60</sub> heteroaryl groups, substituted and unsubstituted C<sub>6</sub>-C<sub>60</sub> condensed polycyclic groups, halogen atoms, cyano groups, hydroxyl groups, and carboxyl groups.

According to other embodiments of the present invention, an organic light-emitting device includes a first electrode, a second electrode, and an organic layer between the first electrode and the second electrode. The organic layer includes at least one organic layer containing the heteroarylamine compound described above.

According to still other embodiments of the present invention, a flat panel display device comprises the organic light-emitting device described above, in which the first electrode of the organic light-emitting device is electrically connected to a source electrode or a drain electrode of a thin film transistor.

According to yet other embodiments of the present invention, an organic light-emitting device includes a first electrode, a second electrode, and an organic layer between the first electrode and the second electrode. The organic layer includes at least one layer including the heteroarylamine compound described above, and the at least one layer is formed using a wet process.

## BRIEF DESCRIPTION OF THE DRAWING

The above and other features and advantages of the present invention will become more apparent by reference to the following detailed description when considered in conjunction with the attached drawing in which:

FIG. 1 is a schematic view of an organic light-emitting device according to an embodiment of the present invention; and

FIG. 2 is a cross-sectional view of a flat panel display according to an embodiment of the present invention.

## DETAILED DESCRIPTION OF THE INVENTION

According to embodiments of the present invention, a heteroarylamine compound is represented by Formula 1 below. In some embodiments, the heteroarylamine compound may be used to form an organic layer of an organic light-emitting device (OLED).

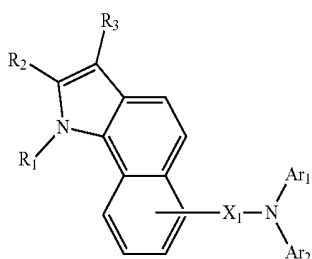

Formula 1

In Formula 1, each of Ar<sub>1</sub> and Ar<sub>2</sub> is independently selected from substituted and unsubstituted C<sub>6</sub>-C<sub>60</sub> aryl groups, substituted and unsubstituted C<sub>4</sub>-C<sub>60</sub> heteroaryl groups, and substituted and unsubstituted C<sub>6</sub>-C<sub>60</sub> condensed polycyclic groups. X<sub>1</sub> is selected from substituted and unsubstituted C<sub>6</sub>-C<sub>30</sub> arylene groups (for example, C<sub>6</sub>-C<sub>18</sub> arylene groups), substituted and unsubstituted C<sub>4</sub>-C<sub>30</sub> heteroarylene groups (for example, C<sub>5</sub>-C<sub>20</sub> heteroarylene groups), and substituted and unsubstituted C<sub>6</sub>-C<sub>20</sub> condensed polycyclic groups. Each of R<sub>1</sub>, R<sub>2</sub> and R<sub>3</sub> is independently selected from hydrogen, heavy hydrogen, substituted and unsubstituted C<sub>1</sub>-C<sub>50</sub> alkyl groups, substituted and unsubstituted C<sub>1</sub>-C<sub>50</sub> alkoxy groups, substituted and unsubstituted C<sub>1</sub>-C<sub>50</sub> alkoxycarbonyl groups, substituted and unsubstituted C<sub>6</sub>-C<sub>60</sub> aryl groups, substituted and unsubstituted C<sub>5</sub>-C<sub>50</sub> aryloxy groups, substituted and unsubstituted C<sub>5</sub>-C<sub>50</sub> arylthio groups, —N(R)(R') groups (wherein each of R and R' is independently selected from substituted and unsubstituted C<sub>1</sub>-C<sub>50</sub> alkyl groups and substituted and unsubstituted C<sub>6</sub>-C<sub>50</sub> aryl groups), substituted and unsubstituted C<sub>5</sub>-C<sub>50</sub> carbocyclic groups, substituted and unsubstituted C<sub>4</sub>-C<sub>60</sub> heteroaryl groups, substituted and unsubstituted C<sub>6</sub>-C<sub>60</sub> condensed polycyclic groups, halogen atoms, cyano groups, hydroxyl groups, and carboxyl groups.

Nonlimiting examples of the arylene group or the heteroarylene group represented by X<sub>1</sub> include phenylene groups, 1-naphthylene groups, 2-naphthylene groups, 1-anthrylene groups, 2-anthrylene groups, 9-anthrylene groups, 1-phenanthrylene groups, 2-phenanthrylene groups, 3-phenanthrylene groups, 4-phenanthrylene groups, 9-phenanthrylene groups, 1-naphthacenylylene groups, 2-naphthacenylylene groups, 9-naphthacenylylene groups, 1-pyrenylene groups, 2-pyrenylene groups, 4-pyrenylene groups, 2-biphenylene groups, 3-biphenylene groups, 4-biphenylene groups, p-terphenyl-4-ylene groups, p-terphenyl-3-ylene groups, p-terphenyl-2-ylene groups, m-terphenyl-4-ylene groups, m-terphenyl-3-ylene groups, m-terphenyl-2-ylene groups, o-tolylylene groups, m-tolylylene groups, p-tolylylene groups, p-t-butylphenylene groups, p-(2-phenylpropyl)phenylene groups, 3-methyl-2-naphthylene groups, 4-methyl-1-naphthylene groups, 4-methyl-1-anthrylene groups, 4'-methylbiphenyl groups, 4"-t-butyl-p-terphenyl-4-ylene groups, fluoranthenylylene groups, fluorenylylene groups, 1-pyrrolylene groups, 2-pyrrolylene groups, 3-pyrrolylene groups, pyrazinylylene groups, 2-pyridinylylene groups, 3-pyridinylylene groups, 4-pyridinylylene groups, 1-indolylylene groups, 2-indolylylene groups, 3-indolylylene groups, 4-indolylylene groups,

5-indolylylene groups, 6-indolylylene groups, 7-indolylylene groups, 1-isoindolylylene groups, 2-isoindolylylene groups, 3-isoindolylylene groups, 4-isoindolylylene groups, 5-isoindolylylene groups, 6-isoindolylylene groups, 7-isoindolylylene groups, 2-furylylene groups, 3-furylylene groups, 2-benzofuranylylene groups, 3-benzofuranylylene groups, 4-benzofuranylylene groups, 5-benzofuranylylene groups, 6-benzofuranylylene groups, 7-benzofuranylylene groups, 1-isobenzofuranylylene groups, 3-isobenzofuranylylene groups, 4-isobenzofuranylylene groups, 5-isobenzofuranylylene groups, 6-isobenzofuranylylene groups, 7-isobenzofuranylylene groups, quinolylylene groups, 3-quinolylylene groups, 4-quinolylylene groups, 5-quinolylylene groups, 6-quinolylylene groups, 7-quinolylylene groups, 8-quinolylylene groups, 1-isoquinolylylene groups, 3-isoquinolylylene groups, 4-isoquinolylylene groups, 5-isoquinolylylene groups, 6-isoquinolylylene groups, 7-isoquinolylylene groups, 8-isoquinolylylene groups, 2-quinoxalinylylene groups, 5-quinoxalinylylene groups, 6-quinoxalinylylene groups, 1-carbazolylylene groups, 2-carbazolylylene groups, 3-carbazolylylene groups, 4-carbazolylylene groups, 9-carbazolylylene groups, 1-phenanthridinylylene groups, 2-phenanthridinylylene groups, 3-phenanthridinylylene groups, 4-phenanthridinylylene groups, 6-phenanthridinylylene groups, 7-phenanthridinylylene groups, 8-phenanthridinylylene groups, 9-phenanthridinylylene groups, 10-phenanthridinylylene groups, 1-acridinylylene groups, 2-acridinylylene groups, 3-acridinylylene groups, 4-acridinylylene groups, 9-acridinylylene groups, 1,7-phenanthroline-2-ylene groups, 1,7-phenanthroline-3-ylene groups, 1,7-phenanthroline-4-ylene groups, 1,7-phenanthroline-5-ylene groups, 1,7-phenanthroline-6-ylene groups, 1,7-phenanthroline-8-ylene groups, 1,7-phenanthroline-9-ylene groups, 1,7-phenanthroline-10-ylene groups, 1,8-phenanthroline-2-ylene groups, 1,8-phenanthroline-3-ylene groups, 1,8-phenanthroline-4-ylene groups, 1,8-phenanthroline-5-ylene groups, 1,8-phenanthroline-6-ylene groups, 1,8-phenanthroline-7-ylene groups, 1,8-phenanthroline-9-ylene groups, 1,8-phenanthroline-10-ylene groups, 1,9-phenanthroline-2-ylene groups, 1,9-phenanthroline-3-ylene groups, 1,9-phenanthroline-4-ylene groups, 1,9-phenanthroline-5-ylene groups, 1,9-phenanthroline-6-ylene groups, 1,9-phenanthroline-7-ylene groups, 1,9-phenanthroline-8-ylene groups, 1,9-phenanthroline-10-ylene groups, 1,10-phenanthroline-2-ylene groups, 1,10-phenanthroline-3-ylene groups, 1,10-phenanthroline-4-ylene groups, 1,10-phenanthroline-5-ylene groups, 2,9-phenanthroline-1-ylene groups, 2,9-phenanthroline-3-ylene groups, 2,9-phenanthroline-4-ylene groups, 2,9-phenanthroline-5-ylene groups, 2,9-phenanthroline-6-ylene groups, 2,9-phenanthroline-7-ylene groups, 2,9-phenanthroline-8-ylene groups, 2,9-phenanthroline-10-ylene groups, 2,8-phenanthroline-1-ylene groups, 2,8-phenanthroline-3-ylene groups, 2,8-phenanthroline-4-ylene groups, 2,8-phenanthroline-5-ylene groups, 2,8-phenanthroline-6-ylene groups, 2,8-phenanthroline-7-ylene groups, 2,8-phenanthroline-9-ylene groups, 2,8-phenanthroline-10-ylene groups, 2,7-phenanthroline-1-ylene groups, 2,7-phenanthroline-3-ylene groups, 2,7-phenanthroline-4-ylene groups, 2,7-phenanthroline-5-ylene groups, 2,7-phenanthroline-6-ylene groups, 2,7-phenanthroline-8-ylene groups, 2,7-phenanthroline-9-ylene groups, 2,7-phenanthroline-10-ylene groups, 1-phenazinylylene groups, 2-phenazinylylene groups, 1-phenothiazinylylene groups, 2-phenothiazinylylene groups, 3-phenothiazinylylene groups, 4-phenothiazinylylene groups, 10-phenothiazinylylene groups, 1-phenoxazinylylene groups, 2-phenoxazinylylene groups, 3-phenoxazinylylene groups, 4-phenoxazinylylene groups, 10-phenoxazinylylene groups, 2-oxazolylylene groups, 4-oxazolylylene groups, 5-oxazolylylene groups, 2-oxadiaz-

5

olylene groups, 5-oxadiazolylene groups, 3-furazanylene groups, 2-thienylene groups, 3-thienylene groups, 2-methylpyrrol-1-ylene groups, 2-methylpyrrol-3-ylene groups, 2-methylpyrrol-4-ylene groups, 2-methylpyrrol-5-ylene groups, 3-methylpyrrol-1-ylene groups, 3-methylpyrrol-2-ylene groups, 3-methylpyrrol-4-ylene groups, 3-methylpyrrol-5-ylene groups, 2-t-butylpyrrol-4-ylene groups, 3-(2-phenylpropyl)pyrrol-1-ylene groups, 2-methyl-1-indolylene groups, 4-methyl-1-indolylene groups, 2-methyl-3-indolylene groups, 4-methyl-3-indolylene groups, 2-t-butyl-1-indolylene groups, 4-t-butyl-1-indolylene groups, 2-t-butyl-3-indolylene groups, and 4-t-butyl-3-indolylene groups.

Nonlimiting examples of the arylene group represented by X1 include phenylene groups, biphenylene groups, terphenylene groups, quarterphenylene groups, naphthylene groups, anthracenylene groups, phenanthrylene groups, chrysenylene groups, pyrenylene groups, perylenylene groups, and fluorenylene groups. In some embodiments, for example, the arylene group may be selected from phenylene groups, biphenylene groups, naphthylene groups, anthracenylene groups, phenanthrylene groups, and fluorenylene groups.

Nonlimiting examples of the heteroarylene group represented by X1 include thiophenylene groups, 1-phenylthiophenylene groups, 1,4-diphenylthiophenylene groups, benzothiophenylene groups, 1-phenylbenzothiophenylene groups, 1,8-diphenylbenzothiophenylene groups, furylene groups, 1-phenyldibenzothiophenylene groups, 1,8-diphenyldibenzothiophenylene groups, dibenzofuranylene groups, 1-phenyldibenzofuranylene groups, 1,8-diphenyldibenzofuranylene groups, and benzothiazolylene groups. In some embodiments, for example, the heteroarylene group may be selected from 1-phenylthiophenylene groups, 1-phenylbenzothiophenylene groups, 1-phenyldibenzofuranylene groups, and benzothiazolylene groups.

In Formula 1, X<sub>1</sub> functions as a linker. When the heteroarylamine compound is used as a material for injecting and transporting holes, the linker stabilizes radical cations generated during voltage application, and thus increases the lifetime of the device. However, when a single benzene ring (such as in m-MTDATA [4,4',4''-tris(3-methylphenyl)phenylamino] triphenylamine], TDATA, or 2-TNATA) includes two nitrogen atoms directly substituted in para-position on the benzene ring without a linker (such as X<sub>1</sub>), the device may not have a satisfactory lifetime. Nonlimiting examples of the linker may include bivalent organic groups represented by the following formulae.

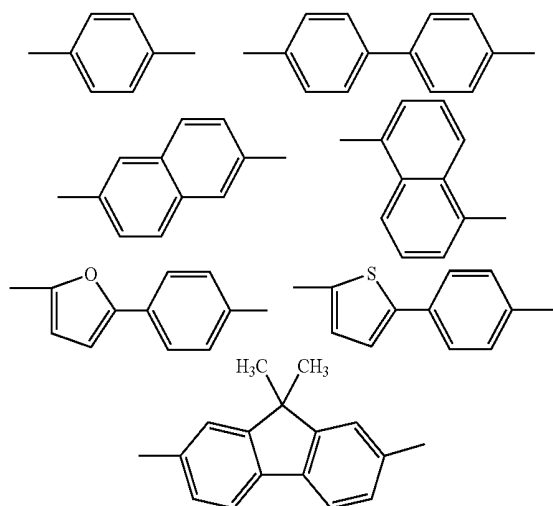

6

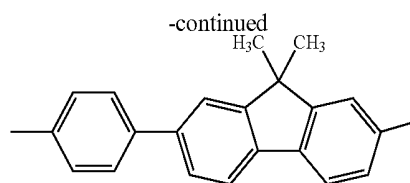

In Formula 1, each of Ar<sub>1</sub> and Ar<sub>2</sub> is independently selected from unsubstituted and substituted C<sub>6</sub>-C<sub>60</sub> aryl groups (for example, aryl groups having from 6 to 18 carbon atoms forming an aromatic ring), and unsubstituted and substituted C<sub>4</sub>-C<sub>60</sub> heteroaryl groups (for example, heteroaryl groups having from 5 to 20 carbon atoms forming an aromatic ring).

Nonlimiting examples of the aryl group represented by Ar<sub>1</sub> or Ar<sub>2</sub> include phenyl groups, 1-naphthyl groups, 2-naphthyl groups, 1-anthracenyl groups, 2-anthracenyl groups, 9-anthracenyl groups, 1-phenanthryl groups, 2-phenanthryl groups, 3-phenanthryl groups, 4-phenanthryl groups, 9-phenanthryl groups, 1-naphthacenyl groups, 2-naphthacenyl groups, 9-naphthacenyl groups, 1-pyrenyl groups, 2-pyrenyl groups, 4-pyrenyl groups, 2-biphenyl groups, 3-biphenyl groups, 4-biphenyl groups, p-terphenyl-4-yl groups, p-terphenyl-3-yl groups, p-terphenyl-2-yl groups, m-terphenyl-4-yl groups, m-terphenyl-3-yl groups, and m-terphenyl-2-yl groups.

Nonlimiting examples of the heteroaryl group represented by Ar<sub>1</sub> or Ar<sub>2</sub> include thiophenyl groups, 1-phenylthiophenyl groups, 1,4-diphenylthiophenyl groups, benzothiophenyl groups, 1-phenylbenzothiophenyl groups, 1,8-diphenylbenzothiophenyl groups, furyl groups, 1-phenyldibenzothiophenyl groups, 1,8-diphenyldibenzothiophenyl groups, dibenzofuranyl groups, 1-phenyldibenzofuranyl groups, 1,8-diphenyldibenzofuranyl groups, and benzothiazolyl groups.

In Formula 1 above, R<sub>1</sub> may be selected from substituted and unsubstituted C<sub>6</sub>-C<sub>60</sub> aryl groups (for example, aryl groups having from 6 to 18 carbon atoms forming an aromatic ring).

Nonlimiting examples of the aryl group represented by R1 include phenyl groups, 1-naphthyl groups, 2-naphthyl groups, 1-anthracenyl groups, 2-anthracenyl groups, 9-anthracenyl groups, 1-phenanthryl groups, 2-phenanthryl groups, 3-phenanthryl groups, 4-phenanthryl groups, 9-phenanthryl groups, 1-naphthacenyl groups, 2-naphthacenyl groups, 9-naphthacenyl groups, 1-pyrenyl groups, 2-pyrenyl groups, 4-pyrenyl groups, 2-biphenyl groups, 3-biphenyl groups, 4-biphenyl groups, p-terphenyl-4-yl groups, p-terphenyl-3-yl groups, p-terphenyl-2-yl groups, m-terphenyl-4-yl groups, m-terphenyl-3-yl groups, m-terphenyl-2-yl groups, o-tolyl groups, m-tolyl groups, p-tolyl groups, p-t-butylphenyl groups, p-(2-phenylpropyl)phenyl groups, 3-methyl-2-naphthyl groups, 4-methyl-1-naphthyl groups, 4-methyl-1-anthryl groups, 4'-methylbiphenyl groups, and 4''-t-butyl-p-terphenyl 4-yl groups. In some embodiments, for example, the aryl group may be selected from phenyl groups, 1-naphthyl groups, 2-naphthyl groups, 4-biphenyl groups, and p-terphenyl-4-yl groups. In other exemplary embodiments, the aryl group may be selected from phenyl groups, biphenyl groups, terphenyl groups, α-naphthyl groups, β-naphthyl groups, and phenanthryl groups.

In Formula 1 above, each of R<sub>2</sub> and R<sub>3</sub> may be independently selected from hydrogen atoms, heavy hydrogen atoms, substituted and unsubstituted C<sub>6</sub>-C<sub>60</sub> (for example, C<sub>6</sub>-C<sub>30</sub>) aryl groups, substituted and unsubstituted C<sub>1</sub>-C<sub>50</sub> (for example, C<sub>1</sub>-C<sub>20</sub>) alkyl groups, substituted and unsubstituted C<sub>1</sub>-C<sub>50</sub> (for example, C<sub>1</sub>-C<sub>20</sub>) alkoxy groups, substituted and

unsubstituted (for example, C<sub>1</sub>-C<sub>20</sub>) alkoxy carbonyl groups, substituted and unsubstituted C<sub>5</sub>-C<sub>50</sub> (for example, C<sub>6</sub>-C<sub>20</sub>) aryloxy groups, substituted and unsubstituted C<sub>5</sub>-C<sub>50</sub> (for example, C<sub>6</sub>-C<sub>20</sub>) arylthio groups, —N(R)(R') groups (wherein each of R and R' is independently selected from substituted and unsubstituted C<sub>1</sub>-C<sub>50</sub> alkyl groups and substituted and unsubstituted C<sub>6</sub>-C<sub>50</sub> aryl groups), halogen atoms, cyano groups, nitro groups, hydroxyl groups, and carboxyl groups.

In Formula 1 above, each of R<sub>2</sub> and R<sub>3</sub> may be selected from substituted and unsubstituted C<sub>6</sub>-C<sub>60</sub> aryl groups linked to an indole backbone at the 2- or 3-position, wherein the aryl group forms an aromatic ring.

Nonlimiting examples of the aryl group represented by R<sub>2</sub> or R<sub>3</sub> include phenyl groups, 1-naphthyl groups, 2-naphthyl groups, 1-anthracenyl groups, 2-anthracenyl groups, 9-anthracenyl groups, 1-phenanthryl groups, 2-phenanthryl groups, 3-phenanthryl groups, 4-phenanthryl groups, 9-phenanthryl groups, 1-naphthacenyl groups, 2-naphthacenyl groups, 9-naphthacenyl groups, 1-pyrenyl groups, 2-pyrenyl groups, 4-pyrenyl groups, 2-biphenyl groups, 3-biphenyl groups, 4-biphenyl groups, p-terphenyl-4-yl groups, p-terphenyl-3-yl groups, p-terphenyl-2-yl groups, m-terphenyl-4-yl groups, m-terphenyl-3-yl groups, m-terphenyl-2-yl groups, o-tolyl groups, m-tolyl groups, p-tolyl groups, p-tert-butylphenyl groups, p-(2-phenylpropyl)phenyl groups, 3-methyl-2-naphthyl groups, 4-methyl-1-naphthyl groups, 4-methyl-1-anthryl groups, 4'-methylbiphenyl groups, 4"-tert-butyl-p-terphenyl-4-yl groups, and fluorenyl groups. In some embodiments, for example, the aryl group may be selected from phenyl groups, 1-naphthyl groups, 2-naphthyl groups, 4-biphenyl groups, p-terphenyl-4-yl groups, p-tolyl groups, and fluorenyl groups.

Nonlimiting examples of the aryloxy group represented by R<sub>2</sub> or R<sub>3</sub> include phenoxy groups, 1-naphthoxy groups, 2-naphthoxy groups, 4-biphenyloxy groups, p-terphenyl-4-yloxy groups, and p-tolyloxy groups. In some embodiments, for example, the aryloxy group may be selected from phenoxy groups and 2-naphthoxy groups.

Nonlimiting examples of the arylthio group represented by R<sub>2</sub> or R<sub>3</sub> include phenylthio groups, 1-naphthylthio groups, 2-naphthylthio groups, 4-biphenylthio groups, p-terphenyl-4-ylthio groups, and p-tolylthio groups. In some embodiments, for example, the arylthio group may be selected from phenylthio groups and 2-naphthylthio groups.

Nonlimiting examples of the alkoxy carbonyl group represented by R<sub>2</sub> or R<sub>3</sub> include methoxycarbonyl groups, ethoxycarbonyl groups, n-propoxycarbonyl groups, iso-propoxycarbonyl groups, n-butoxycarbonyl groups, and tert-butoxycarbonyl groups. In some embodiments, for example, the alkoxy carbonyl group may be selected from methoxycarbonyl groups and ethoxycarbonyl groups.

Nonlimiting examples of the aryl group as a substituent of the amino group, and the aryl group represented by R<sub>2</sub> or R<sub>3</sub>, include those groups listed above in connection with the aryl group represented by R<sub>1</sub>.

In Formula 1 above, nonlimiting examples of the halogen atom include fluorine atoms, chlorine atoms, bromine atoms, and iodine atoms.

Each of the groups described above may be further substituted, and may include at least two substituents which may be the same as or different from each other. The at least two substituents may be interconnected to form a ring.

Nonlimiting examples of the substituents for Ar<sub>1</sub>, Ar<sub>2</sub>, R<sub>1</sub>, R<sub>2</sub> and R<sub>3</sub> include alkyl groups, alkenyl groups, alkynyl groups, amino groups, alkoxy groups, aryloxy groups, acyl groups, alkoxy carbonyl groups, aryloxy carbonyl groups,

acyloxy groups, acylamino groups, alkoxy carbonylamino groups, aryloxy carbonylamino groups, sulfonylamino groups, sulfamoyl groups, carbamoyl groups, alkylthio groups, arylthio groups, sulfonyl groups, sulfinyl groups, ureide groups, phosphoricamide groups, hydroxyl groups, mercapto groups, halogen atoms, cyano groups, sulfo groups, carboxyl groups, nitro groups, hydroxamic acid groups, sulfinyl groups, hydrazino groups, imino groups, heterocyclic groups, and silyl groups. These substituents may be further substituted. In some embodiments, for example, Ar<sub>1</sub>, Ar<sub>2</sub>, R<sub>1</sub>, R<sub>2</sub> and R<sub>3</sub> may each include at least two substituents which may be the same or different. The at least two substituents may be interconnected to form a ring.

Nonlimiting examples of the alkyl group include C1-C20 alkyl groups. In some embodiments for example, the alkyl group is selected from C1-C12 alkyl groups. In other embodiments, the alkyl group is selected from C1-C8 alkyl groups. Nonlimiting examples of suitable alkyl groups include methyl groups, ethyl groups, iso-propyl groups, tert-butyl groups, n-octyl groups, n-decyl groups, n-hexadecyl groups, cyclopropyl groups, cyclopentyl groups, and cyclohexyl groups.

Nonlimiting examples of the alkenyl group include C2-C20 alkenyl groups. In some embodiments, for example, the alkenyl group is selected from C2-C12 alkenyl groups. In other embodiments, the alkenyl group is selected from C2-C8 alkenyl groups. Nonlimiting examples of the alkenyl group include vinyl groups, allyl groups, 2-butenyl groups, and 3-pentenyl groups.

Nonlimiting examples of the alkynyl group include C2-C20 alkynyl group. In some embodiments, for example, the alkynyl group is a C2-C12 alkynyl group. In other embodiment, the alkynyl group is selected from C2-C8 alkynyl groups. A nonlimiting example of the alkynyl group is a 3-pentynyl group.

Nonlimiting examples of the amino group include C0-C20 amino groups. In some embodiments, for example, the amino group is a C0-C12 amino group. In other embodiments, the amino group is selected from C0-C6 amino groups. Nonlimiting examples of the amino group include amino groups, methylamino groups, dimethylamino groups, diethylamino groups, diphenylamino groups, and dibenzylamino groups.

Nonlimiting examples of the alkoxy group include C1-C20 alkoxy groups. In some embodiments, for example, the alkoxy group is a C1-C12 alkoxy group. In other embodiments, the alkoxy group is selected from C1-C18 alkoxy groups. Nonlimiting examples of the alkoxy group include methoxy groups, ethoxy groups, and butoxy groups.

Nonlimiting examples of the aryloxy group include C6-C20 aryloxy groups. In some embodiments, for example, the aryloxy group is a C6-C16 aryloxy group. In other embodiments, the aryloxy group is selected from C6-C12 aryloxy groups. Nonlimiting examples of the aryloxy group include phenoxy groups, and 2-naphthoxy groups.

Nonlimiting examples of the acyl group include C1-C20 acyl groups. In some embodiments, for example, the acyl group is a C1-C16 acyl group. In other embodiments, the acyl group is selected from C1-C12 acyl groups. Nonlimiting examples of the acyl group include acetyl groups, benzoyl groups, formyl groups, and pivaloyl groups.

Nonlimiting examples of the alkoxy carbonyl group include C2-C20 alkoxy carbonyl groups. In some embodiments, for example, the alkoxy carbonyl group is a C2-C16 alkoxy carbonyl group. In other embodiments, the alkoxy carbonyl group is selected from C2-C12 alkoxy carbonyl groups. Nonlimiting examples of the alkoxy carbonyl group include methoxycarbonyl groups, and ethoxycarbonyl groups.

Nonlimiting examples of the aryloxy carbonyl group include C7-C20 aryloxy carbonyl groups. In some embodiments, for example, the aryloxy carbonyl group is a C7-C16 aryloxy carbonyl group. In other embodiments, the aryloxy carbonyl group is selected from C7-C10 aryloxy carbonyl groups. A nonlimiting example of the aryloxy carbonyl group is a phenyloxy carbonyl group.

Nonlimiting examples of the acyloxy group include C2-C20 acyloxy groups. In some embodiments, for example, the acyloxy group is a C2-C16 acyloxy group. In other embodiments, the acyloxy group is selected from C2-C10 acyloxy groups. Nonlimiting examples of the acyloxy group include acetoxy groups and benzyloxy groups.

Nonlimiting examples of the acylamino group include C2-C20 acylamino groups. In some embodiments, for example, the acylamino group is a C2-C16 acylamino group. In other embodiments, the acylamino group is selected from C2-C10 acylamino groups. Nonlimiting examples of the acylamino group include acetylamino groups, and benzoylamino groups.

Nonlimiting examples of the alkoxycarbonylamino group include C2-C20 alkoxycarbonylamino groups. In some embodiments, for example, the alkoxycarbonylamino group is a C2-C16 alkoxycarbonylamino group. In other embodiments, the alkoxycarbonylamino group is selected from C2-C12 alkoxycarbonylamino groups. A nonlimiting example of an alkoxycarbonylamino group is a methoxycarbonylamino group.

Nonlimiting examples of the aryloxy carbonylamino group include C7-C20 aryloxy carbonylamino groups. In some embodiments, for example, the aryloxy carbonylamino group is a C7-C16 aryloxy carbonylamino group. In other embodiments, the aryloxy carbonylamino group is selected from C7-C12 aryloxy carbonylamino groups. One nonlimiting example of an aryloxy carbonylamino group is a phenyloxy carbonylamino group.

Nonlimiting examples of the sulfonylamino group include C1-C20 sulfonylamino groups. In some embodiments, for example, the sulfonylamino group is a C1-C16 sulfonylamino group. In other embodiments, the sulfonylamino group is selected from C1-C12 sulfonylamino groups. Nonlimiting examples of the sulfonylamino group include methanesulfonylamino groups, and benzenesulfonylamino groups.

Nonlimiting examples of the sulfamoyl group include C0-C20 sulfamoyl groups. In some embodiments, for example, the sulfamoyl group is a C0-C16 sulfamoyl group. In other embodiments, the sulfamoyl group is selected from C0-C12 sulfamoyl groups. Nonlimiting examples of the sulfamoyl group include sulfamoyl groups, methylsulfamoyl groups, dimethylsulfamoyl groups, and phenylsulfamoyl groups.

Nonlimiting examples of the carbamoyl group include C1-C20 carbamoyl groups. In some embodiment, for example, the carbamoyl group is a C1-C16 carbamoyl group. In other embodiments, the carbamoyl group is selected from C1-C12 carbamoyl groups. Nonlimiting examples of the carbamoyl group include carbamoyl groups, methylcarbamoyl groups, diethylcarbamoyl groups, and phenylcarbamoyl groups.

Nonlimiting examples of the alkylthio group include C1-C20 alkylthio groups. In some embodiments, for example, the alkylthio group is a C1-C16 alkylthio group. In other embodiments, the alkylthio group is selected from C1-C12 alkylthio groups. Nonlimiting examples of the alkylthio group include methylthio groups, and ethylthio groups.

Nonlimiting examples of the arylthio group include C6-C20 arylthio groups. In some embodiments, for example, the arylthio group is a C6-C16 arylthio group. In other embodiments, the arylthio group is selected from C6-C12 arylthio groups. One nonlimiting example of the arylthio group is a phenylthio group.

Nonlimiting examples of the sulfonyl group include C1-C20 sulfonyl groups. In some embodiments, for example, the sulfonyl group is a C1-C16 sulfonyl group. In other embodiments, the sulfonyl group is selected from C1-C12 sulfonyl groups. Nonlimiting examples of the sulfonyl group include mesyl groups, and tosyl groups.

Nonlimiting examples of the sulfinyl group include C1-C20 sulfinyl groups. In some embodiments, for example, the sulfinyl group is a C1-C16 sulfinyl group. In other embodiments, the sulfinyl group is selected from C1-C12 sulfinyl groups. Nonlimiting examples of the sulfinyl group include methanesulfinyl groups, and benzenesulfinyl groups.

Nonlimiting examples of the ureide group include C1-C20 ureide groups. In some embodiments, for example, the ureide group is a C1-C16 ureide group. In other embodiments, the ureide group is selected from C1-C12 ureide groups. Nonlimiting examples of the ureide group include ureide groups, methylureide groups, and phenylureide groups.

Nonlimiting examples of the phosphoricamide group include C1-C20 phosphoricamide group. In some embodiments, for example, the phosphoricamide group is a C1-C16 phosphoricamide group. In other embodiments, the phosphoricamide group is selected from C1-C12 phosphoricamide groups. Nonlimiting examples of the phosphoricamide group include diethylphosphoricamide groups, and phenylphosphoricamide groups.

Nonlimiting examples of the halogen atom include fluorine atoms, chlorine atoms, bromine atoms and iodine atoms.

The heterocyclic group may be a C1-C30 heterocyclic group. In some embodiments, for example, the heterocyclic group is a C1-C15 heterocyclic group. Nonlimiting examples of the heterocyclic group include imidazolyl groups, pyridyl groups, quinolyl groups, furyl groups, thienyl groups, piperidyl groups, morpholino groups, benzoxazolyl groups, benzimidazolyl groups, benzothiazolyl groups, and carbazolyl groups, in which the hetero atom may be nitrogen, oxygen, or sulfur.

Nonlimiting examples of the silyl group include C3-C40 silyl groups. In some embodiments, for example, the silyl group is a C3-C30 silyl group. In other embodiments, the silyl group is selected from C3-C24 silyl groups. Nonlimiting examples of the silyl group include trimethylsilyl groups and triphenylsilyl groups.

In some embodiments of the present invention, the heteroarylamine compound of Formula 1 may include a compound represented by any of Formulae 2 through 6 below.

Formula 2

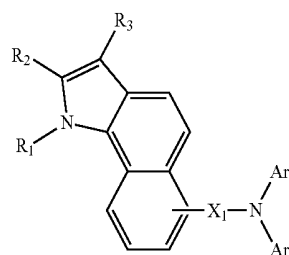

11

-continued

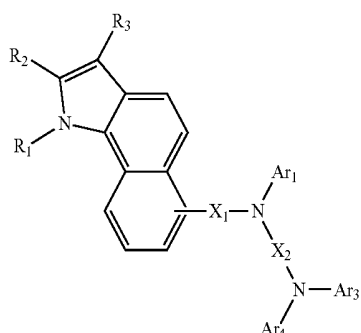

Formula 3

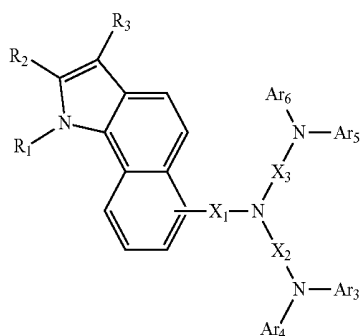

Formula 4

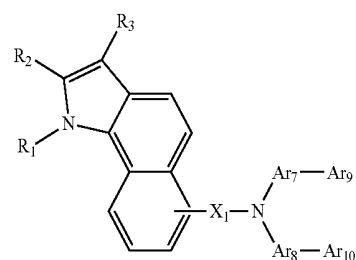

Formula 5

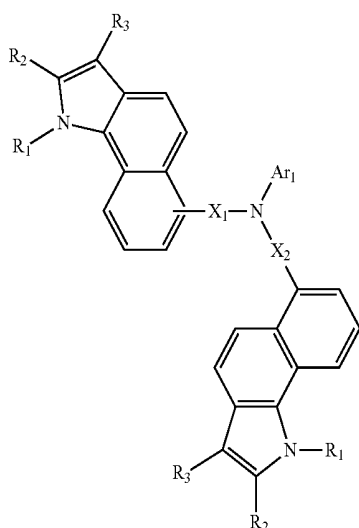

Formula 6

In Formulae 2 through 6, each of Ar<sub>1</sub> through Ar<sub>6</sub>, Ar<sub>9</sub> and Ar<sub>10</sub> is independently selected from substituted and unsubstituted C<sub>6</sub>-C<sub>60</sub> aryl groups, substituted and unsubstituted C<sub>4</sub>-C<sub>60</sub> heteroaryl groups, and substituted and unsubstituted C<sub>6</sub>-C<sub>60</sub> condensed polycyclic groups. Each of X<sub>1</sub> through X<sub>3</sub>, Ar<sub>7</sub> and Ar<sub>8</sub> is independently selected from substituted and unsubstituted C<sub>6</sub>-C<sub>30</sub> arylene groups, substituted and unsubstituted C<sub>4</sub>-C<sub>30</sub> heteroarylene groups, and substituted and unsubstituted C<sub>6</sub>-C<sub>30</sub> condensed polycyclic groups. Each of R<sub>1</sub>, R<sub>2</sub> and R<sub>3</sub> is independently selected from hydrogen,

12

heavy hydrogen, substituted and unsubstituted C<sub>1</sub>-C<sub>50</sub> alkyl groups, substituted and unsubstituted C<sub>1</sub>-C<sub>50</sub> alkoxy groups, substituted and unsubstituted C<sub>1</sub>-C<sub>50</sub> alkoxy carbonyl groups, substituted and unsubstituted C<sub>6</sub>-C<sub>60</sub> aryl groups, substituted and unsubstituted C<sub>5</sub>-C<sub>50</sub> aryloxy groups, substituted and unsubstituted C<sub>5</sub>-C<sub>60</sub> arylthio groups, —N(R)(R') groups (wherein each of R and R' is independently selected from substituted and unsubstituted C<sub>1</sub>-C<sub>50</sub> alkyl groups and substituted and unsubstituted C<sub>6</sub>-C<sub>50</sub> aryl groups), substituted and unsubstituted C<sub>3</sub>-C<sub>50</sub> carbocyclic groups, substituted and unsubstituted C<sub>4</sub>-C<sub>60</sub> heteroaryl groups, substituted and unsubstituted C<sub>6</sub>-C<sub>60</sub> condensed polycyclic groups, halogen atoms, cyano groups, hydroxyl groups, and carboxyl groups.

In Formulae 2 through 6, each of Ar<sub>1</sub> through Ar<sub>6</sub>, Ar<sub>9</sub> and Ar<sub>10</sub> is independently selected from monocyclic to tricyclic aryl groups. Nonlimiting examples of suitable monocyclic to tricyclic aryl groups include phenyl groups, naphthyl groups, biphenyl groups, terphenyl groups, fluorenyl groups, and carbazoyl groups. The monocyclic to tricyclic aryl group may be substituted with from one to three substituents. Nonlimiting examples of these substituents include C<sub>1</sub>-C<sub>5</sub> alkyl groups, C<sub>1</sub>-C<sub>5</sub> alkoxy groups, cyano groups, amino groups, phenoxy groups, phenyl groups, and halogen atoms.

Nonlimiting examples of the arylene group represented by X<sub>1</sub> through X<sub>3</sub> include phenylene groups, biphenylene groups, terphenylene groups, quarterphenylene groups, naphthylene groups, anthracenylene groups, phenanthrylene groups, chrysenylene groups, pyrenylene groups, perylenylene groups, and fluorenylene groups. In some embodiments, for example, the arylene group may be selected from phenylene groups, biphenylene groups, naphthylene groups, anthracenyl groups, phenanthrylene groups, and fluorenylene groups.

Nonlimiting examples of the heteroarylene group represented by X<sub>1</sub> through X<sub>3</sub> include thiophenylene groups, 1-phenylthiophenylene groups, 1,4-diphenylthiophenylene groups, benzothiophenylene groups, 1-phenylbenzothiophenylene groups, 1,8-diphenylbenzothiophenylene groups, furylene groups, 1-phenyldibenzothiophenylene groups, 1,8-diphenylthiophenylene groups, dibenzofuranylene groups, 1-phenyldibenzofuranylene groups, 1,8-diphenyldibenzofuranylene groups, and benzothiazolylene groups. In some embodiments, for example, the heteroarylene group may be selected from 1-phenylthiophenyl groups, 1-phenylbenzothiophenyl groups, 1-phenyldibenzofuranyl groups, and benzothiazolyl groups.

In Formulae 1 through 6, or Formulae 2 through 6, each of R<sub>1</sub> through R<sub>3</sub> is independently an aryl group. For example, each of R<sub>1</sub> through R<sub>3</sub> may be independently selected from phenyl groups, 4-fluorophenyl groups, naphthyl groups, and biphenyl groups.

In Formulae 1 through 6 or Formulae 2 through 6, nonlimiting examples of bivalent organic groups represented by X<sub>1</sub> through X<sub>3</sub> include those represented by the following formulae. Each of X<sub>1</sub> through X<sub>3</sub> may be independently selected from these bivalent organic groups, but are not limited thereto.

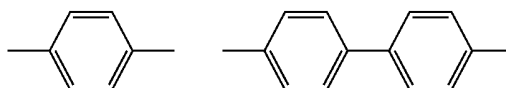

65

66

13

-continued

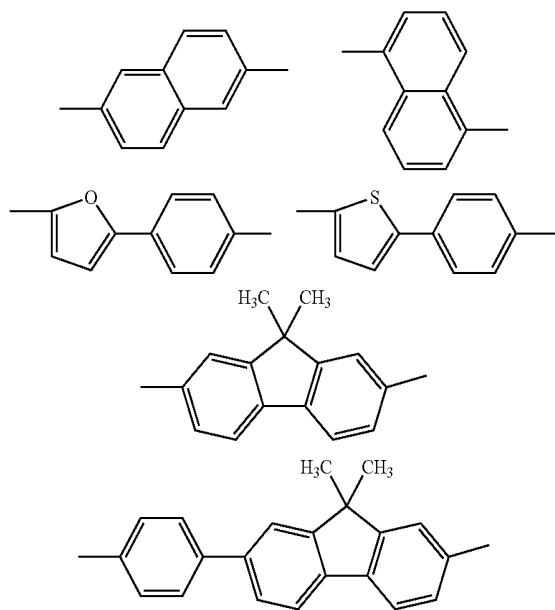

In Formulae 1 through 6 or Formulae 2 through 6, each of Ar<sub>1</sub> through Ar<sub>6</sub>, Ar<sub>9</sub> and Ar<sub>10</sub> may be independently selected from monovalent organic groups represented by the following formulae.

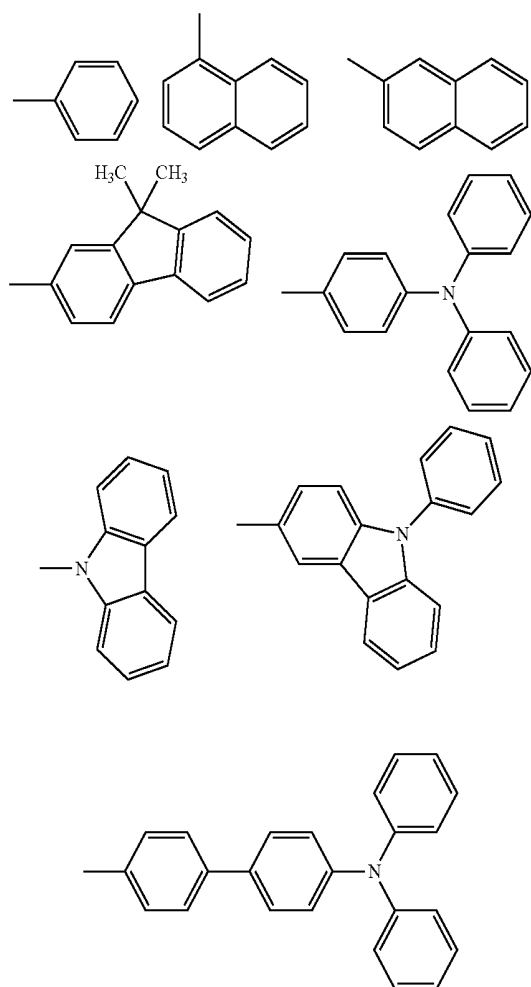

14

-continued

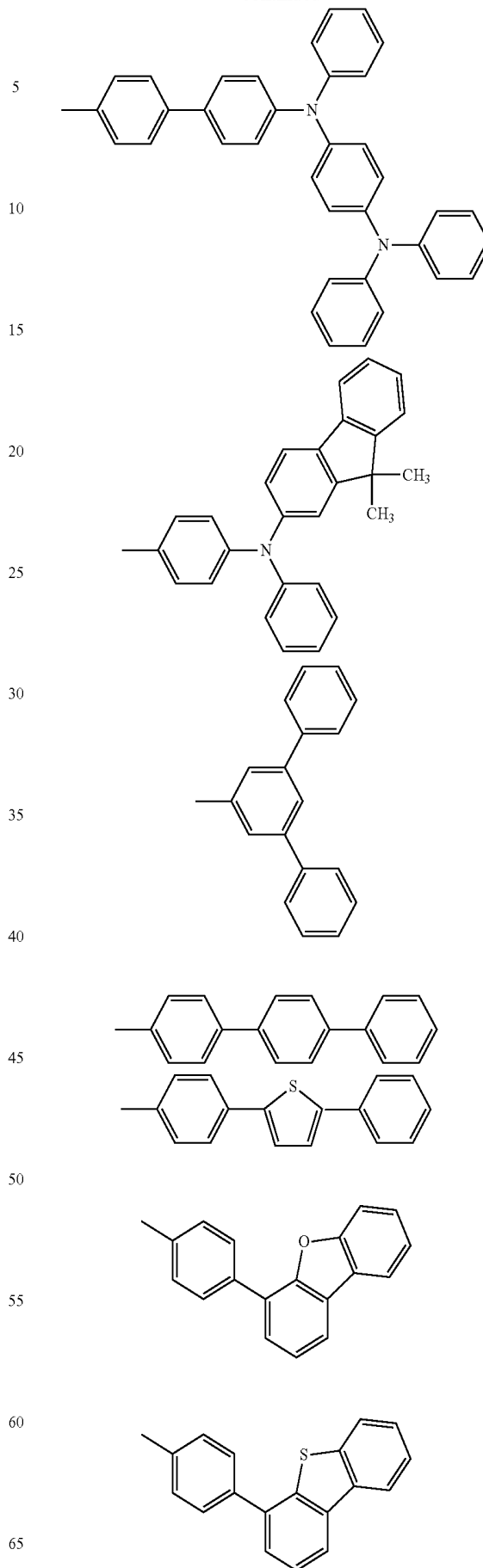

15

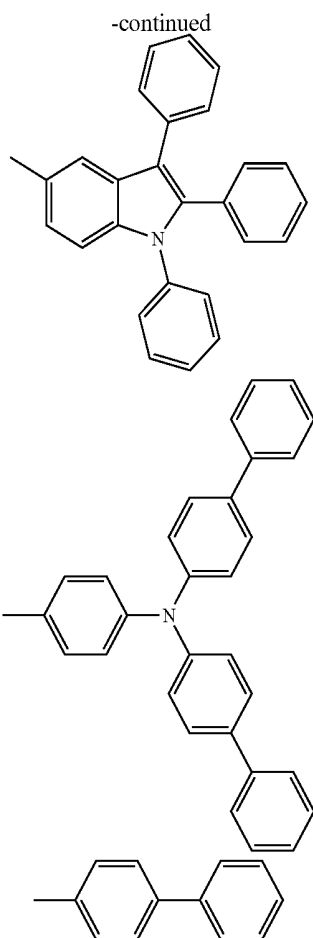

Hereinafter, substituents described with reference to Formulae 1 through 6 will be described.

The unsubstituted  $C_1$ - $C_{50}$  alkyl group may be linear or branched. Nonlimiting examples of the alkyl group include methyl groups, ethyl groups, propyl groups, isobutyl groups, sec-butyl groups, pentyl groups, iso-amyl groups, hexyl groups, heptyl groups, octyl groups, nonanyl groups, and dodecyl groups. At least one hydrogen atom of the alkyl group may be substituted with a substituent selected from heavy hydrogen atoms, halogen atoms, hydroxyl groups, nitro groups, cyano groups, amino groups, amidino groups, hydrazines, hydrazones, carboxyl groups and salts thereof, sulfonic acid groups and salts thereof, phosphoric acid groups and salts thereof,  $C_1$ - $C_{10}$  alkyl groups,  $C_1$ - $C_{10}$  alkoxy groups,  $C_2$ - $C_{10}$  alkenyl groups,  $C_2$ - $C_{10}$  alkynyl groups,  $C_6$ - $C_{16}$  aryl groups, and  $C_4$ - $C_{16}$  heteroaryl groups.

The unsubstituted  $C_3$ - $C_{50}$  carbocyclic group refers to a  $C_3$ - $C_{50}$  cycloalkyl group where at least one hydrogen atom in the carbon ring may be substituted with the substituents described above in connection with the  $C_1$ - $C_{50}$  alkyl group.

The unsubstituted  $C_4$ - $C_{60}$  heterocyclic group refers to a  $C_4$ - $C_{60}$  cycloalkyl group including one, two or three hetero atoms selected from N, O, P and S, where at least one hydrogen atom in the heterocyclic group may be substituted with the substituents described above in connection with the  $C_1$ - $C_{50}$  alkyl group.

The unsubstituted  $C_1$ - $C_{50}$  alkoxy group is a group having a —OA structure where A is an unsubstituted  $C_1$ - $C_{50}$  alkyl group as described above. Nonlimiting examples of the alkoxy group include methoxy groups, ethoxy groups, propoxy groups, isopropoxy groups, butoxy groups, and pentoxy groups. At least one hydrogen atom of the alkoxy group

16

may be substituted with the substituents described above in connection with the  $C_1$ - $C_{50}$  alkyl group.

The unsubstituted  $C_6$ - $C_{60}$  aryl group refers to a carbocyclic aromatic system containing at least one ring. At least two rings may be fused to each other or linked to each other by a single bond. The term 'aryl' refers to an aromatic system, such as phenyl, naphthyl, or anthracenyl. At least one hydrogen atom in the aryl group may be substituted with the substituents described above in connection with the  $C_1$ - $C_{50}$  alkyl group.

Nonlimiting examples of the substituted or unsubstituted  $C_6$ - $C_{60}$  aryl group include phenyl groups,  $C_1$ - $C_{10}$  alkylphenyl groups (for example, ethylphenyl groups), halophenyl groups (for example, o-, m-, and p-fluorophenyl groups, dichlorophenyl groups), cyanophenyl groups, dicyanophenyl groups, trifluoromethoxyphenyl groups, biphenyl groups, halobiphenyl groups, cyanobiphenyl groups,  $C_1$ - $C_{10}$  alkyl biphenyl groups,  $C_1$ - $C_{10}$  alkoxybiphenyl groups, o-, m-, and p-toryl groups, o-, m-, and p-cumenyl groups, mesityl groups, phenoxyphenyl groups, ( $\alpha,\alpha$ -dimethylbenzene)phenyl groups, (N,N'-dimethyl)aminophenyl groups, (N,N'-diphenyl)aminophenyl groups, pentalenyl groups, indenyl groups, naphthyl groups, halonaphthyl groups (for example, fluoronaphthyl groups),  $C_1$ - $C_{10}$  alkyl naphthyl groups (for example, methyl naphthyl groups),  $C_1$ - $C_{10}$  alkoxy naphthyl groups (for example, methoxy naphthyl groups), cyanonaphthyl groups, anthracenyl groups, azulenyl groups, heptalenyl groups, acenaphthylenyl groups, phenalenyl groups, fluorenyl groups, anthraquinolyl groups, methylanthryl groups, phenanthryl groups, triphenylene groups, pyrenyl groups, chrysenyl groups, ethyl-chrysenyl groups, picenyl groups, perylenyl groups, chloroperlylenyl groups, pentaphenyl groups, pentacenyl groups, tetraphenylenyl groups, hexaphenyl groups, hexacenyl groups, rubicenyl groups, coronenyl groups, trinaphthylenyl groups, heptaphenyl groups, heptacenyl groups, pyranthrenyl groups, and ovalenyl groups.

The unsubstituted  $C_4$ - $C_{60}$  heteroaryl group includes one, two or three hetero atoms selected from N, O, P and S. At least two rings may be fused to each other or linked to each other by a single bond. Nonlimiting examples of the unsubstituted  $C_4$ - $C_{60}$  heteroaryl group include pyrazolyl groups, imidazolyl groups, oxazolyl groups, thiazolyl groups, triazolyl groups, tetrazolyl groups, oxadiazolyl groups, pyridinyl groups, pyridazinyl groups, pyrimidinyl groups, triazinyl groups, carbazolyl groups, indolyl groups, quinolinyl groups, and isoquinolinyl groups. At least one hydrogen atom in the heteroaryl group may be substituted with the substituents described above in connection with the  $C_1$ - $C_{50}$  alkyl group.

The unsubstituted  $C_6$ - $C_{60}$  condensed polycyclic group refers to a substituent including at least two rings where at least one aromatic ring and/or at least one non-aromatic ring are fused to each other. The unsubstituted  $C_6$ - $C_{60}$  polycyclic condensed group may include some of the substituents described in connection with the aryl group or the heteroaryl group.

The heteroarylamine compound of Formula 1 may be used as an organic layer material having at least one of hole-injecting capability, hole-transporting capability, and light-emitting capability.

The heteroarylamine compound of Formula 1 has a heterocyclic group in the molecule, and therefore has a high glass transition temperature (T<sub>g</sub>) or melting point due to the introduction of the heterocyclic group. Thus, the heteroarylamine compound has high heat resistance against Joule's heat generated in an organic layer, between organic layers, or between an organic layer and a metallic electrode when light emission occurs. The heteroarylamine compound also has high durability in a high-temperature environment. An organic light-

17

emitting device manufactured using the heteroarylamine compound has high durability when stored or operated.

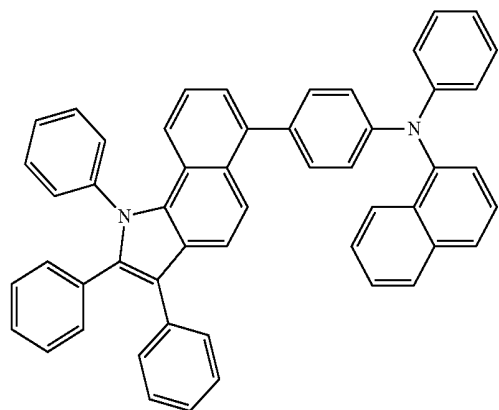

18

Nonlimiting examples of the heteroarylamine compound of Formula 1 include the following Compounds 1-121.

1

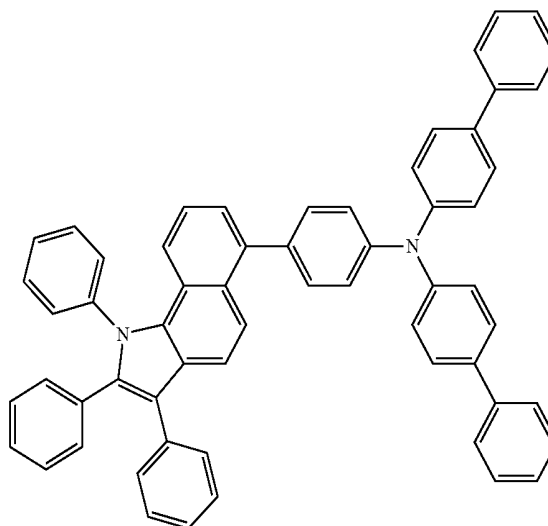

2

3

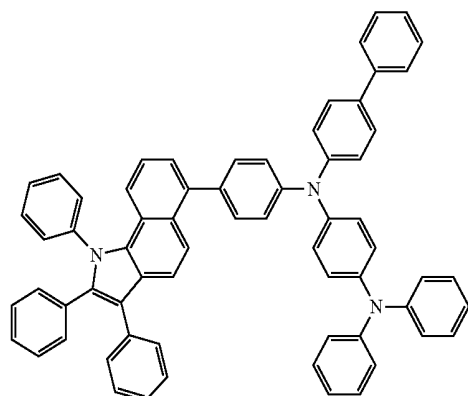

4

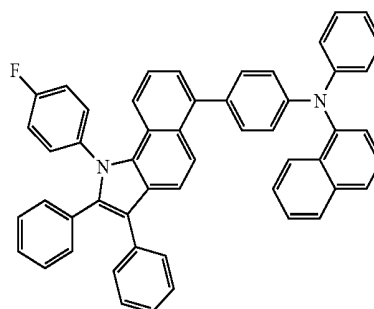

5

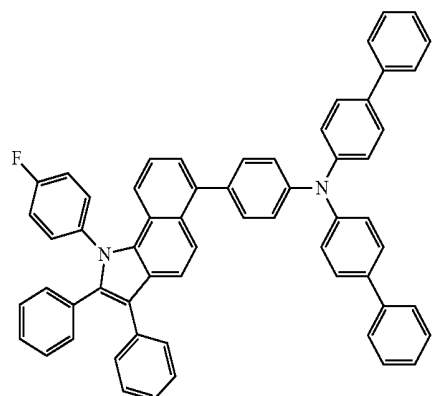

6

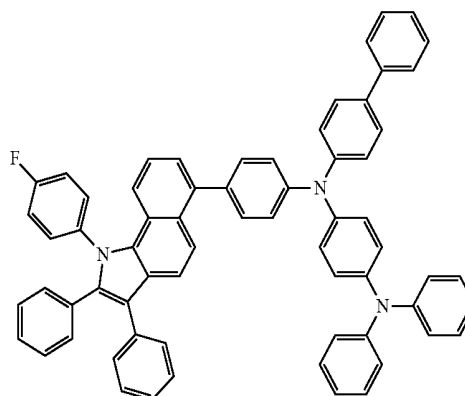

19

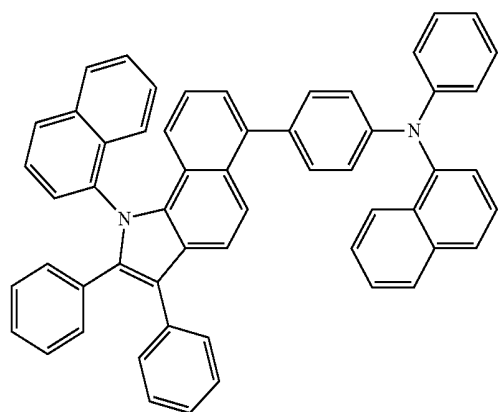

-continued  
7

20

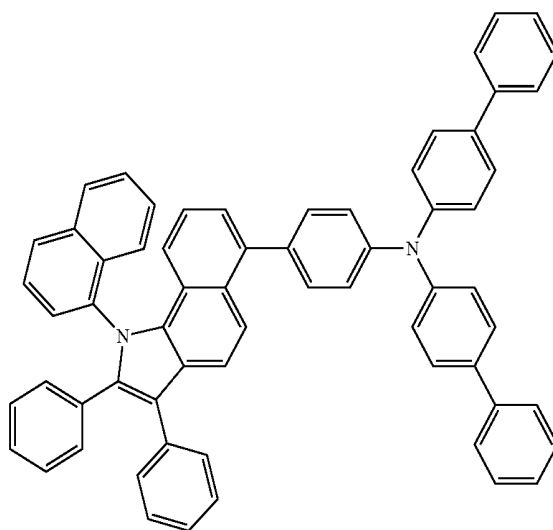

8

9

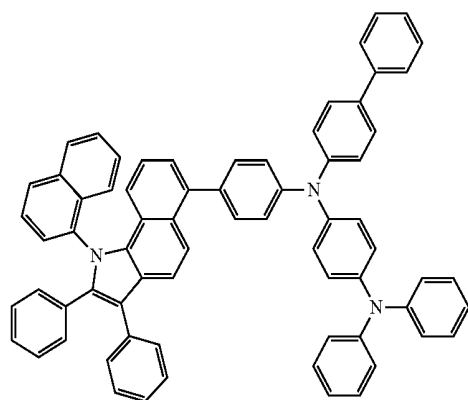

10

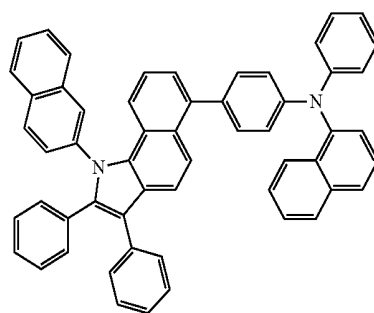

11

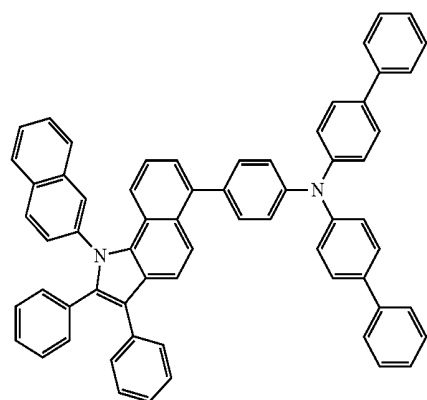

12

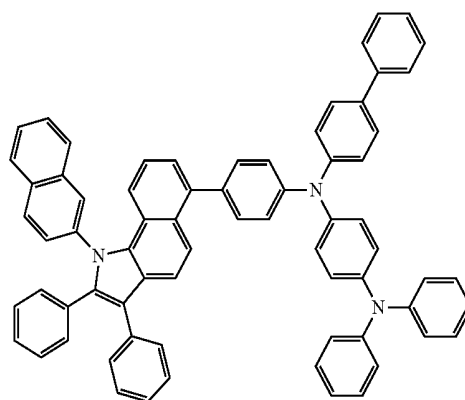

13

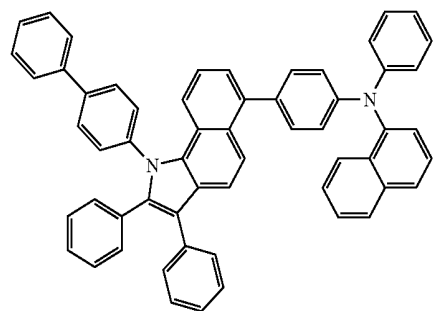

14

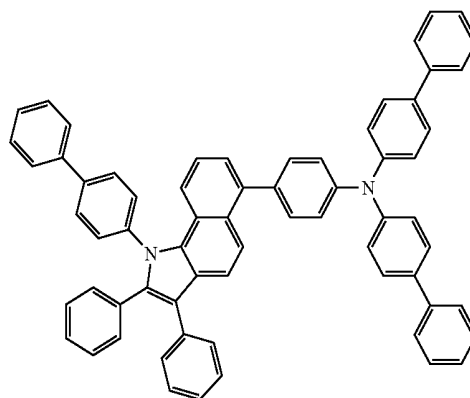

21

22

-continued

15

16

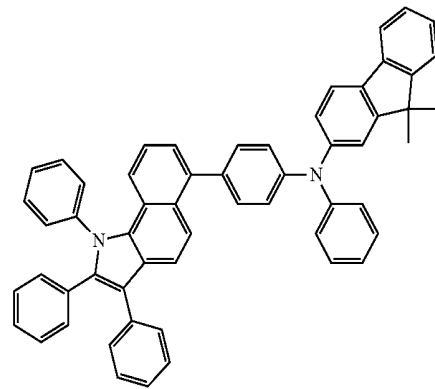
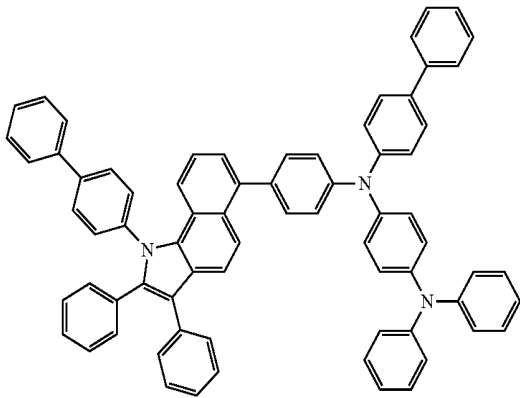

17

18

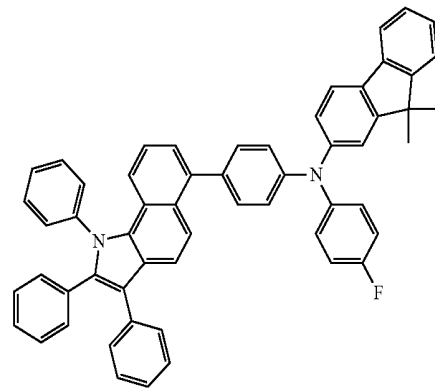
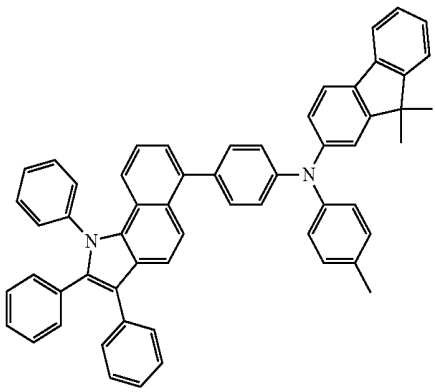

19

20

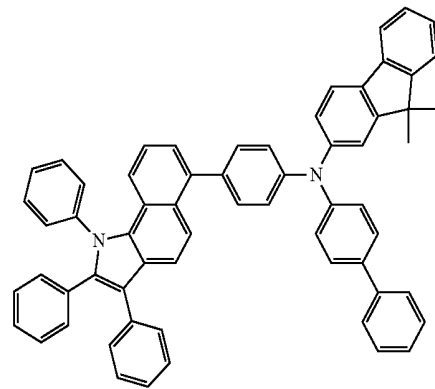
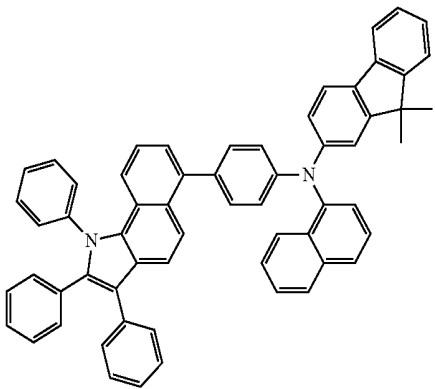

21

22

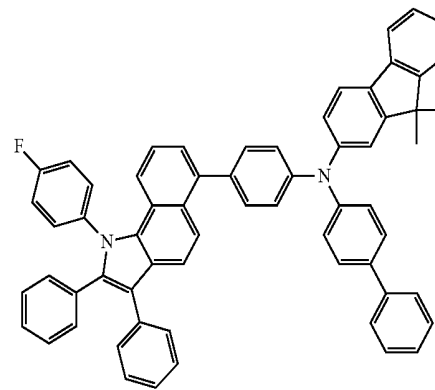
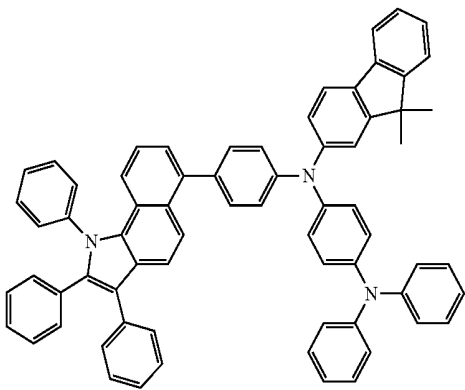

23

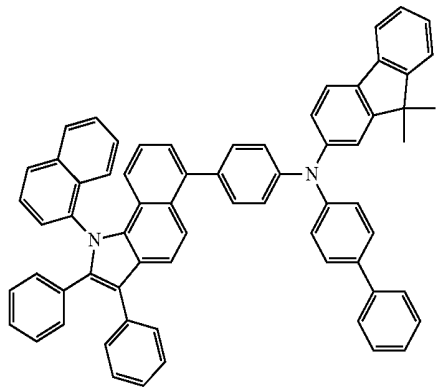

-continued

23

24

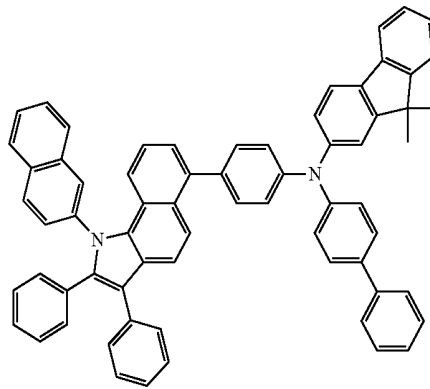

24

25

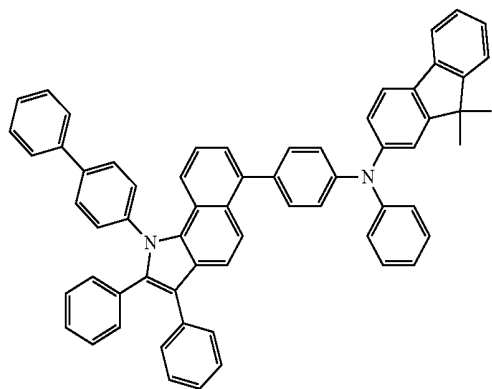

26

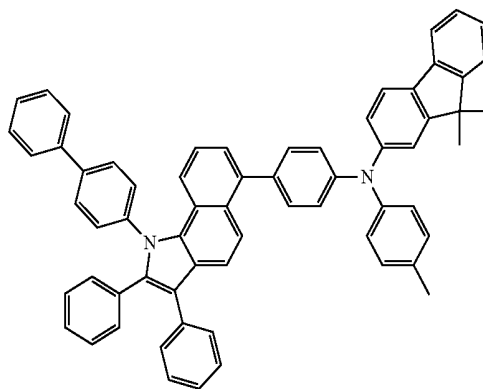

27

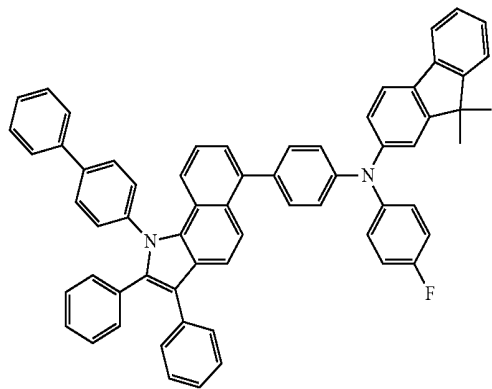

28

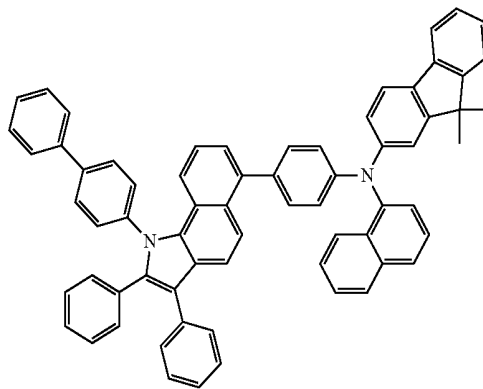

29

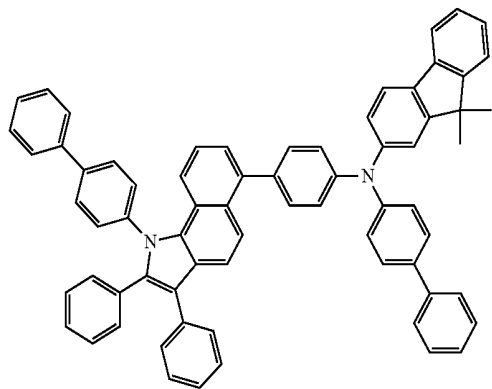

30

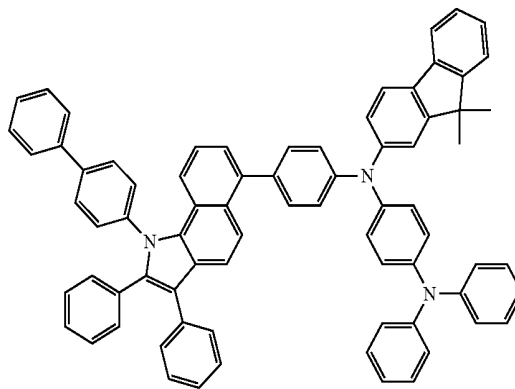

25

26

-continued

31

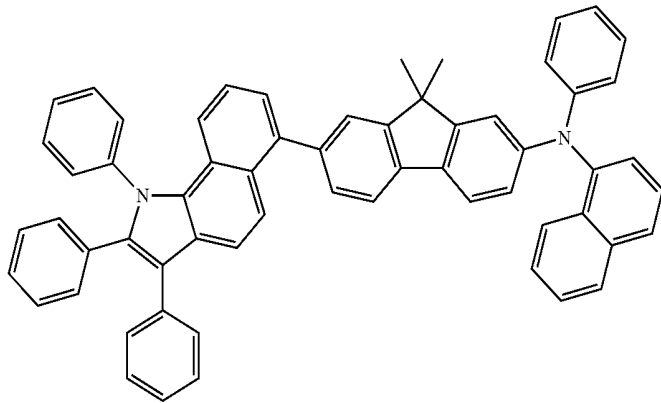

32

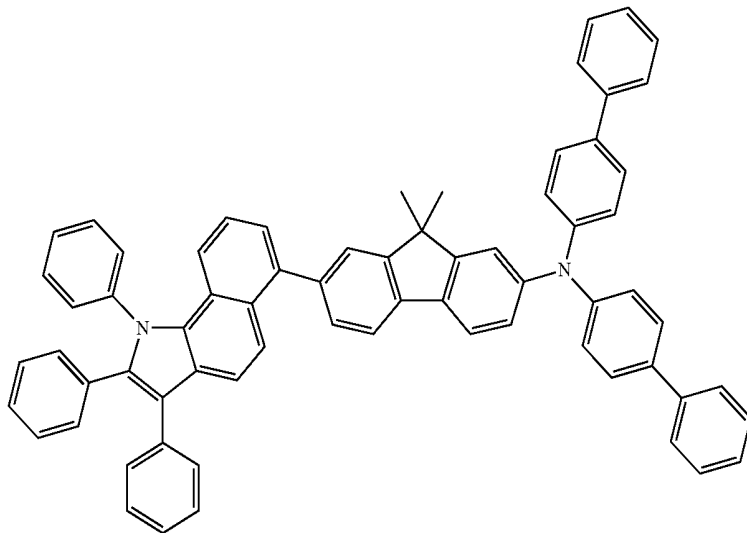

33

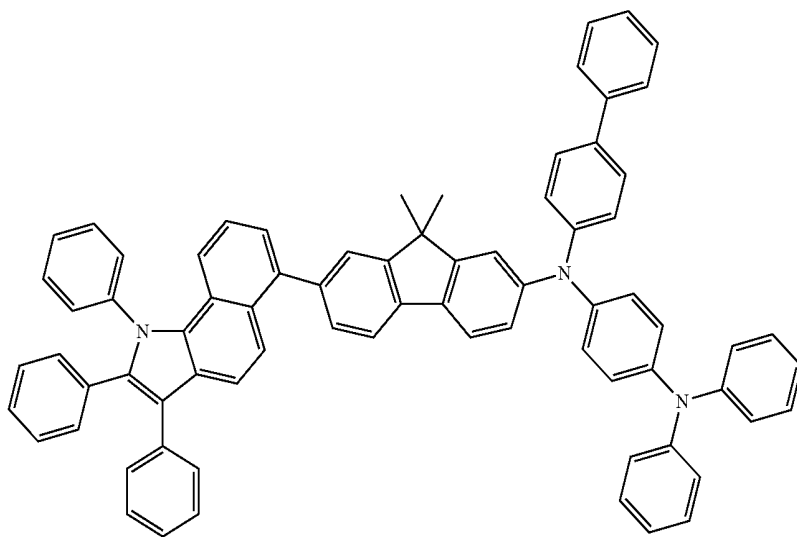

27

28

-continued

34

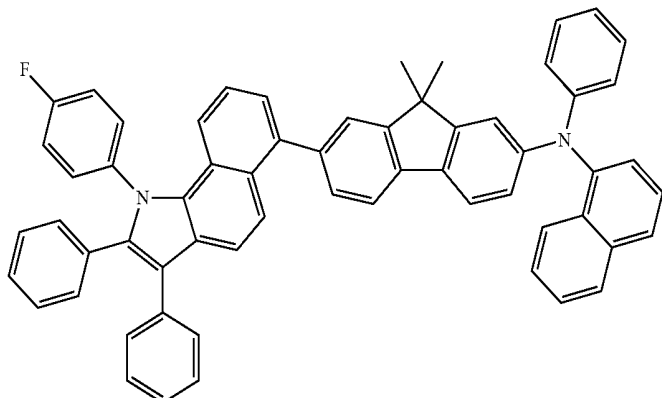

35

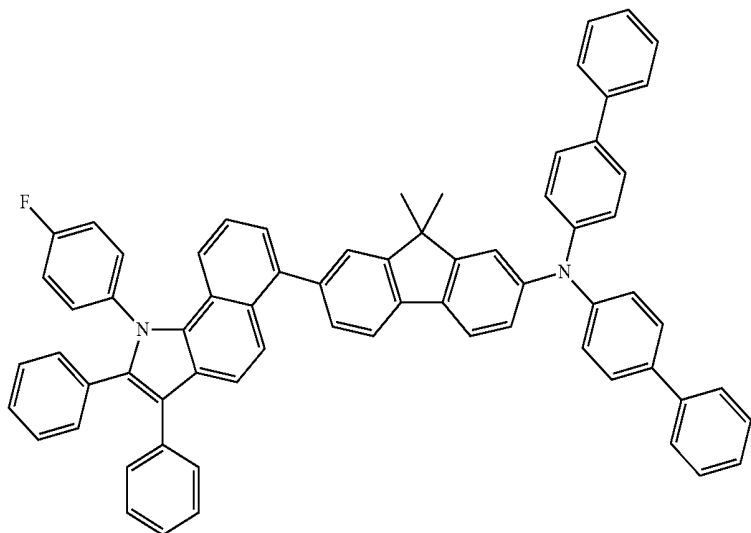

36

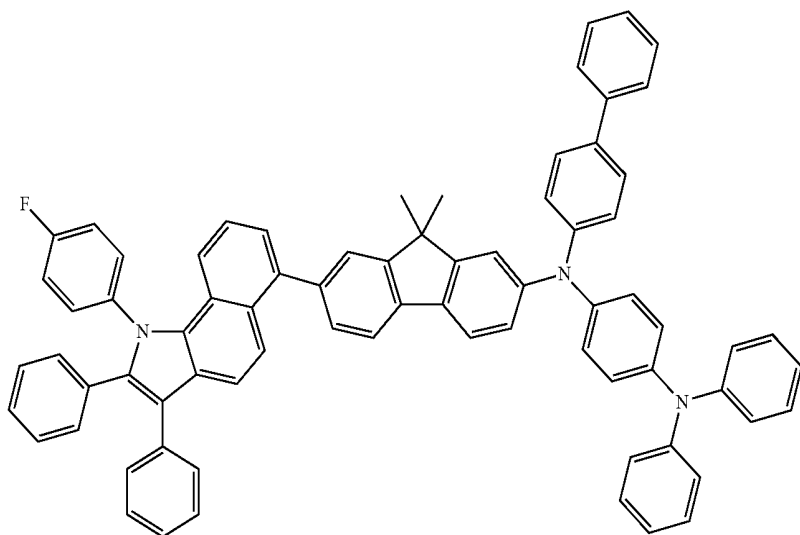

29

30

-continued

37

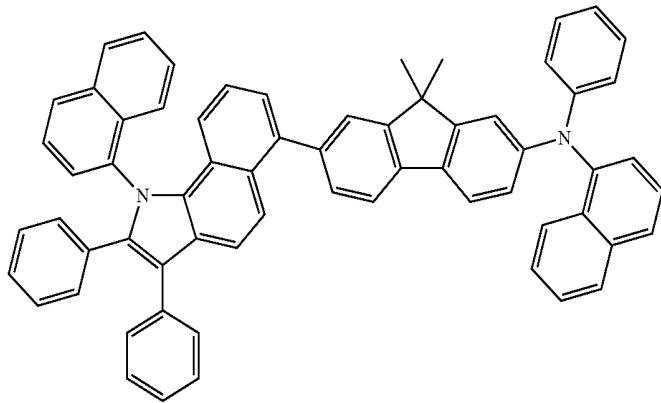

38

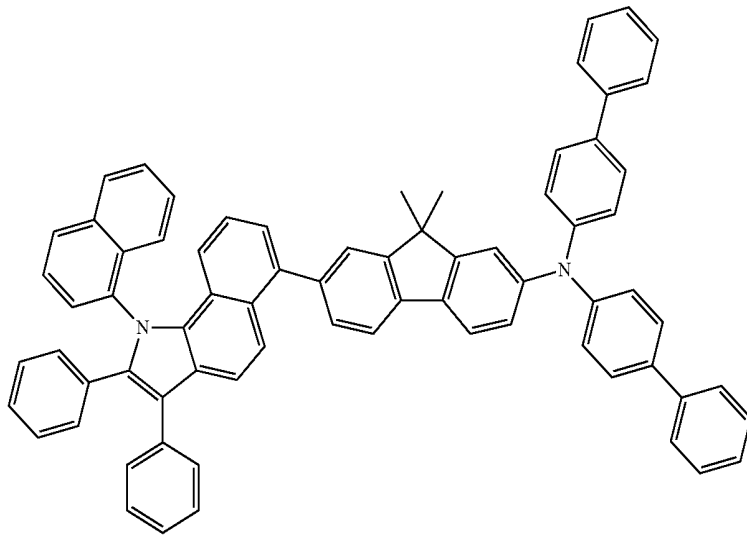

39

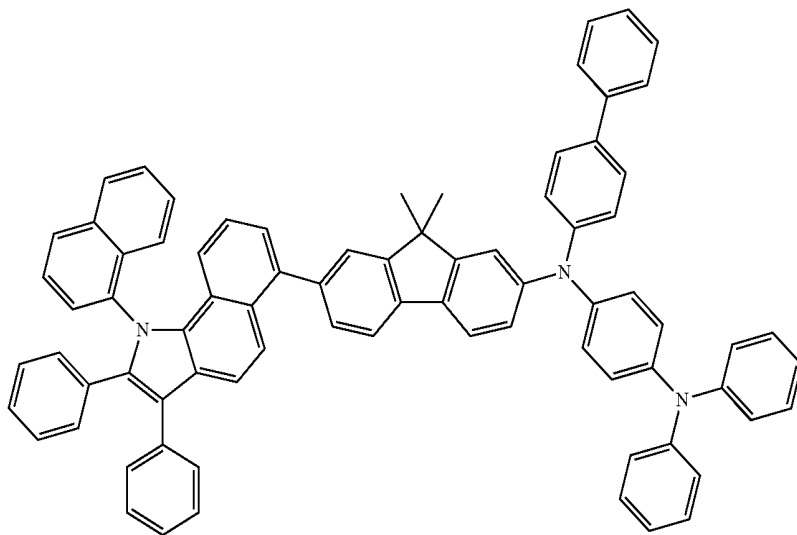

31

32

-continued

40

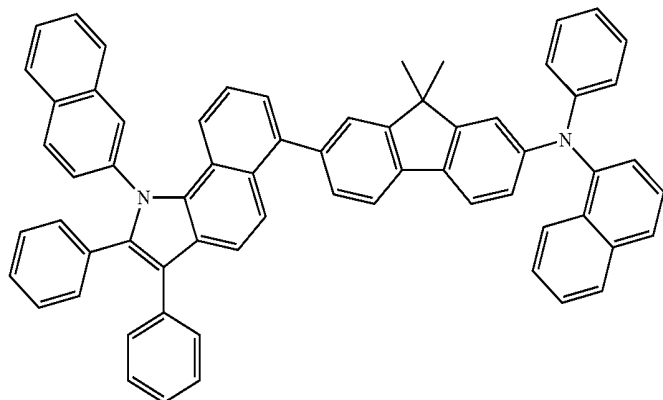

41

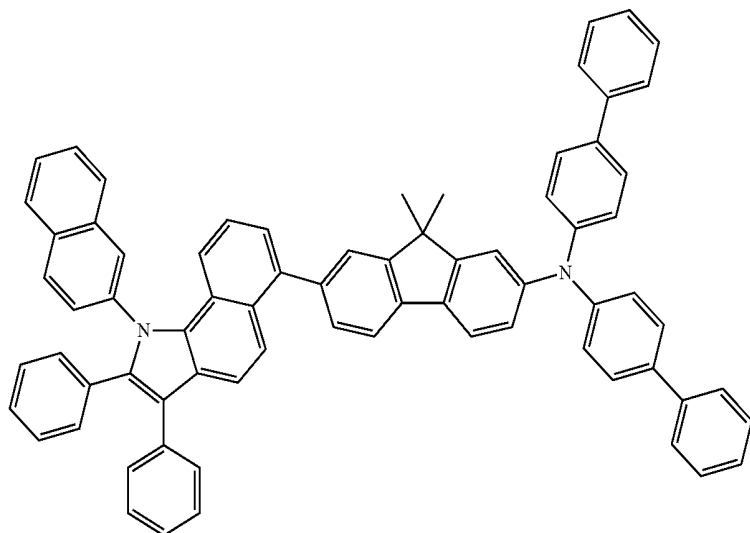

42

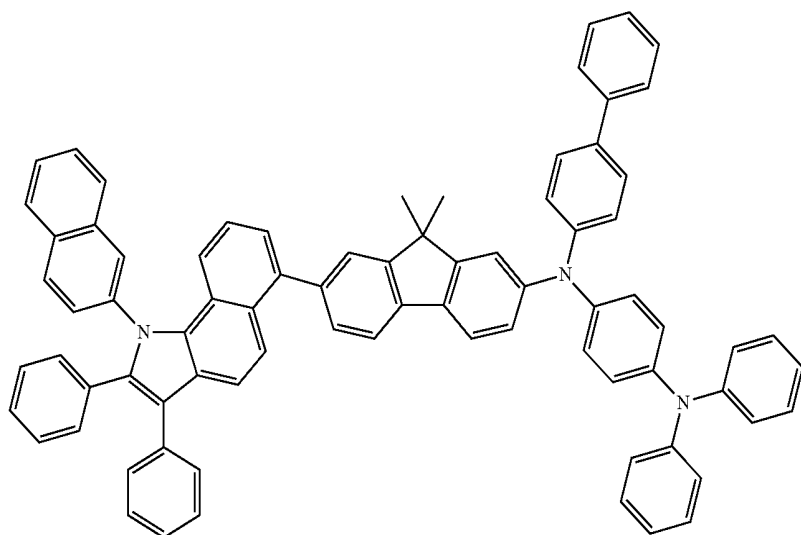



35

36

-continued

46

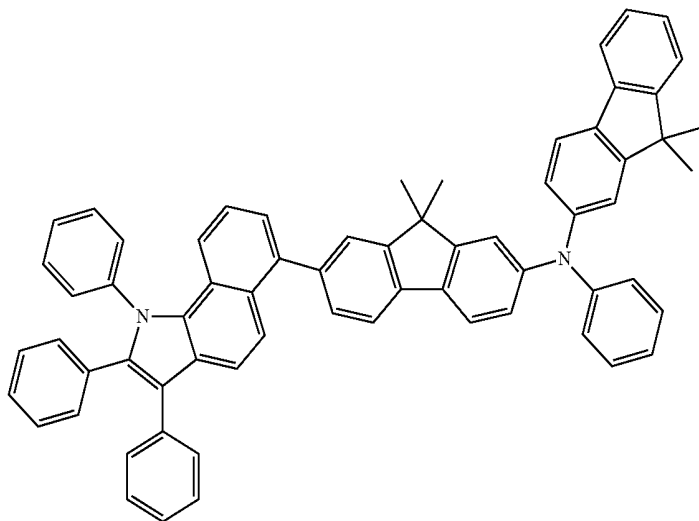

47

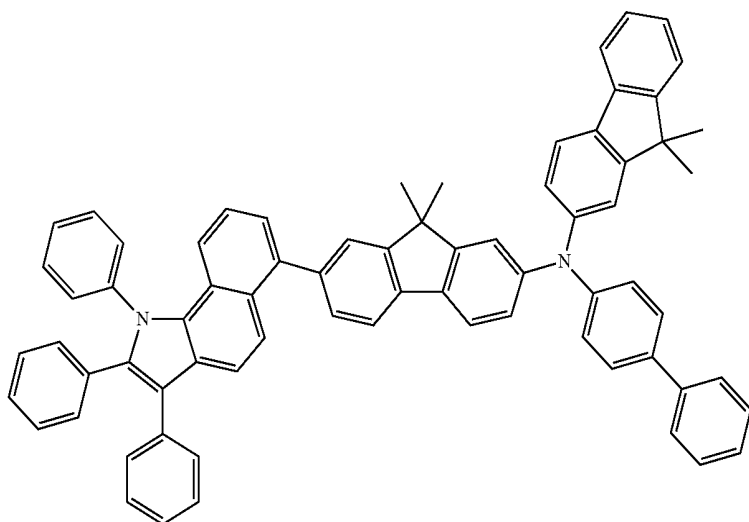

48

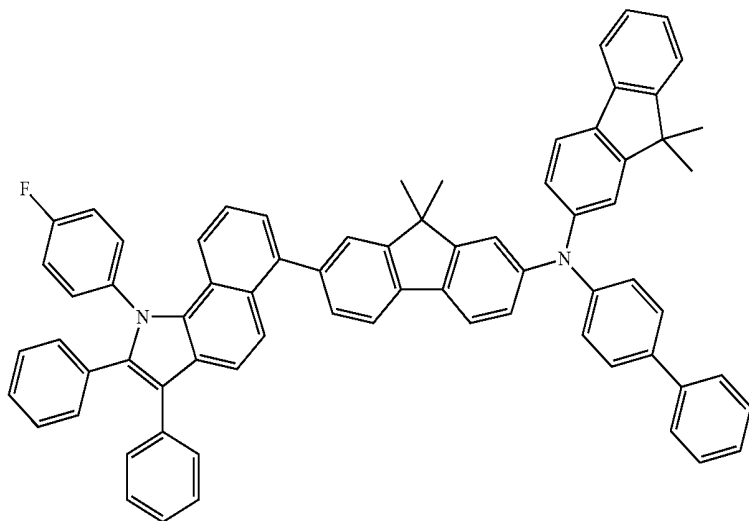

37

38

-continued

49

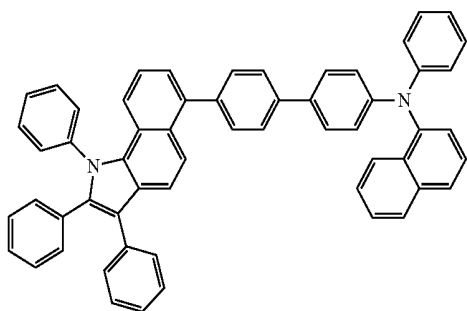
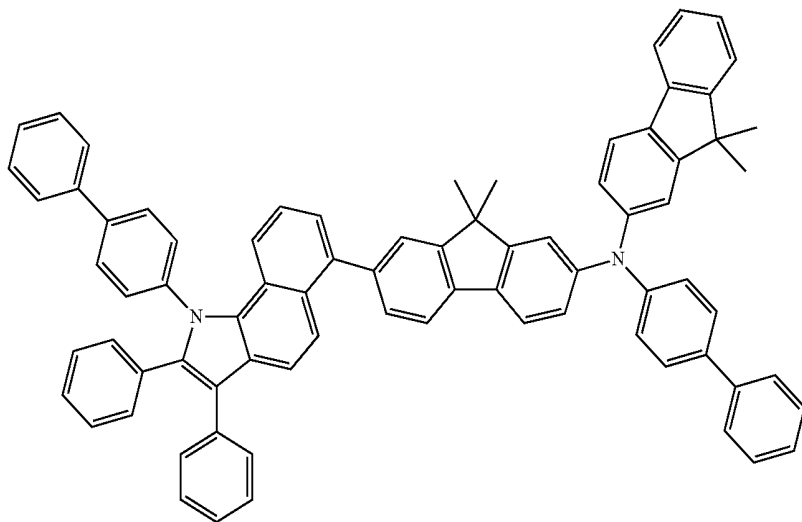

50

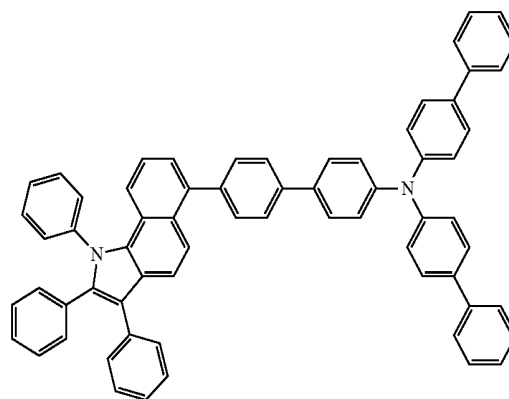

51

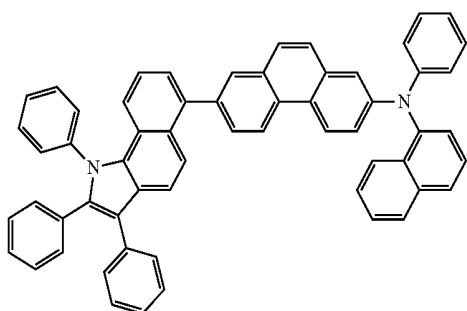

52

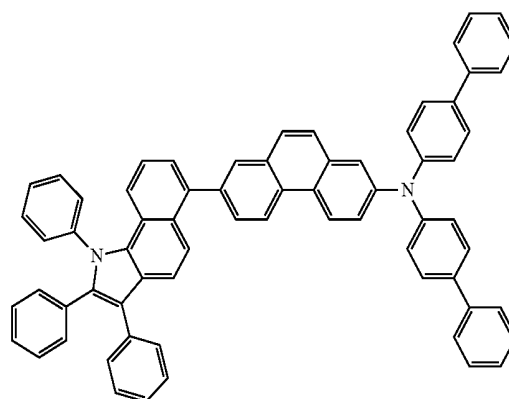

53

39

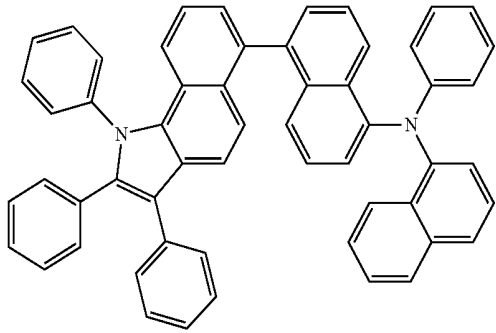

-continued

54

40

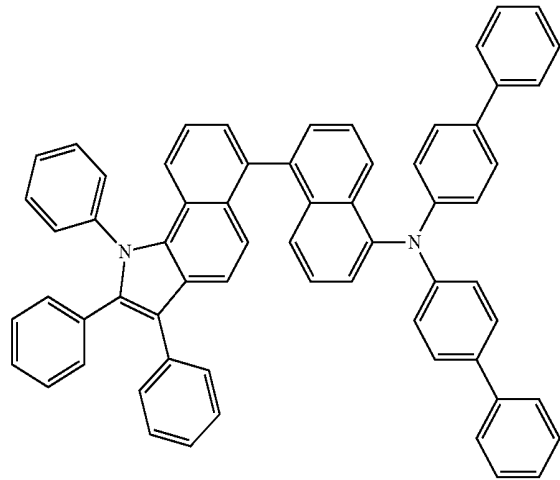

55

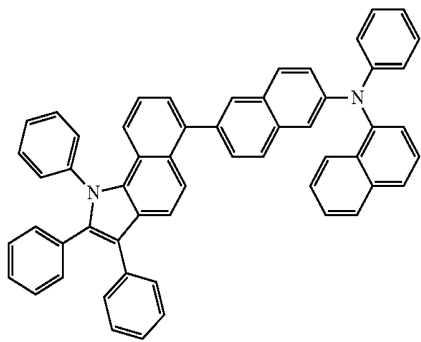

56

57

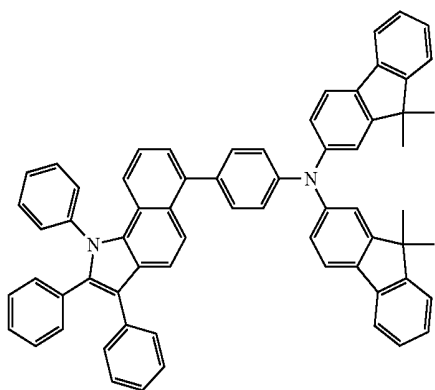
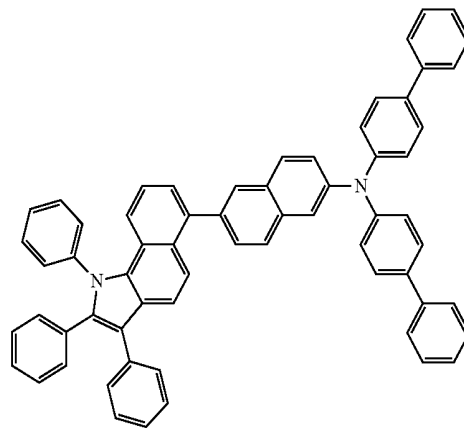

58

59

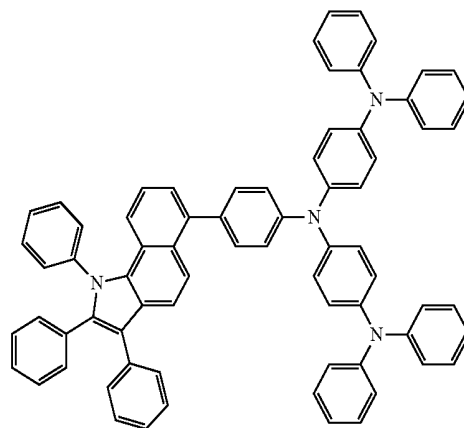

41

42

-continued  
60

61

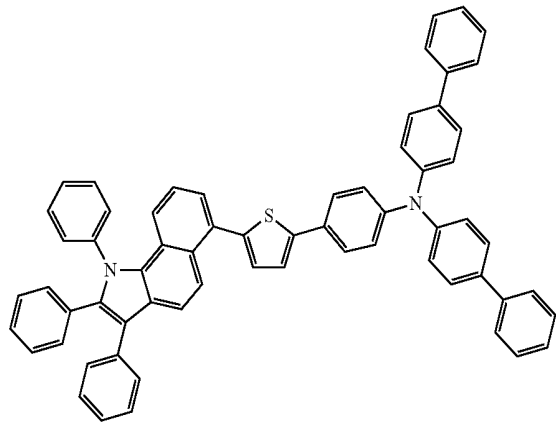
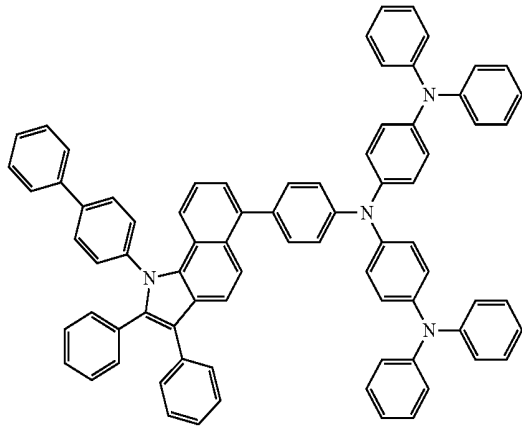

62

63

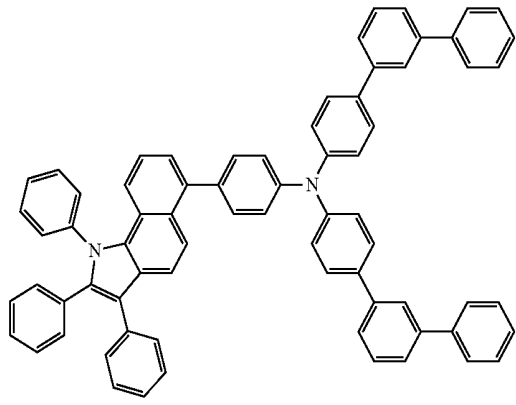
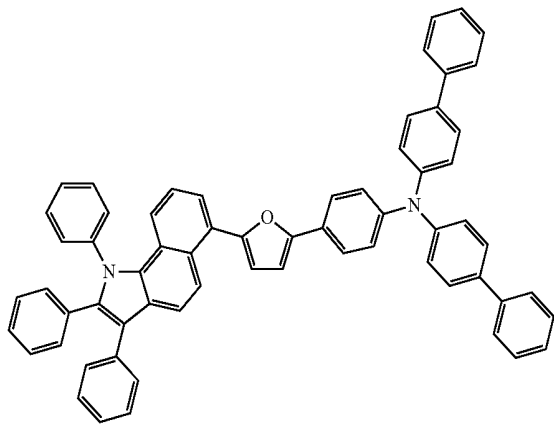

64

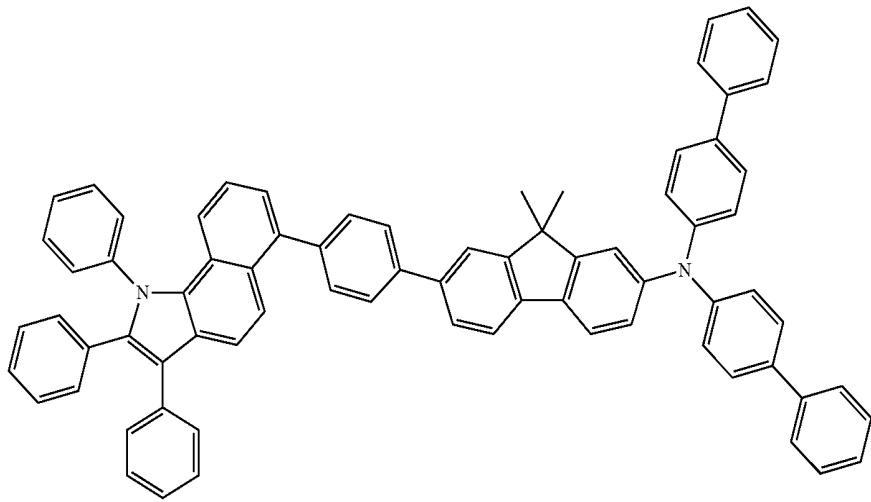

43

44

-continued

65

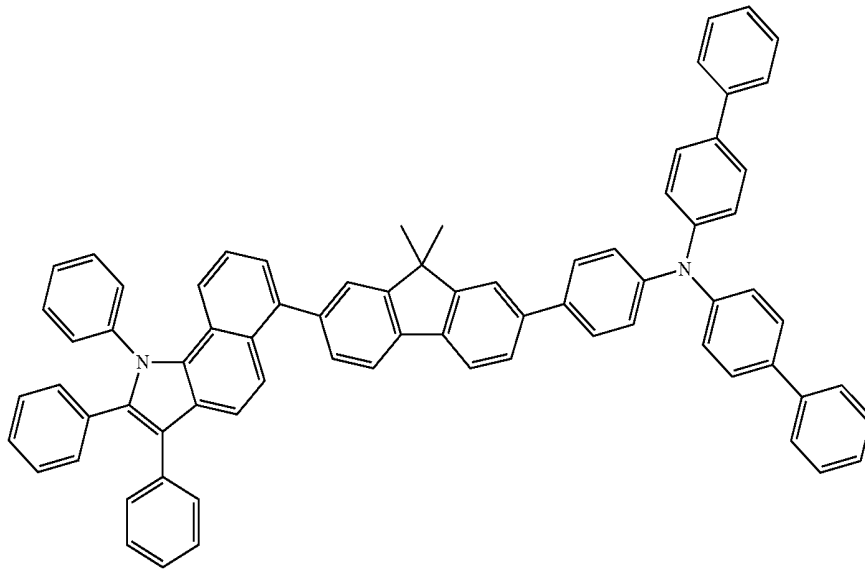

66

67

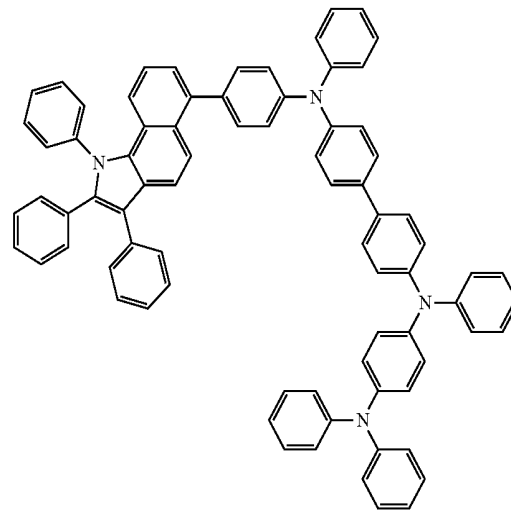
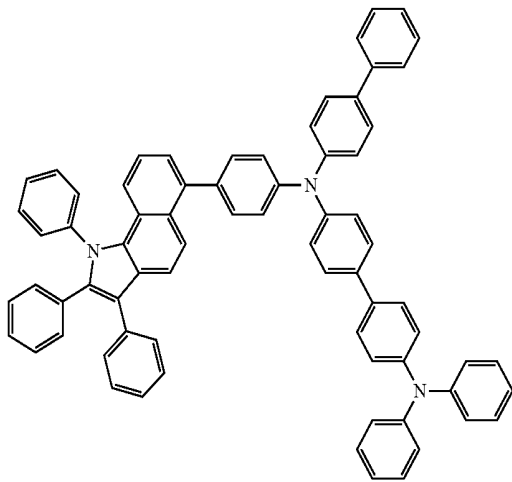

68

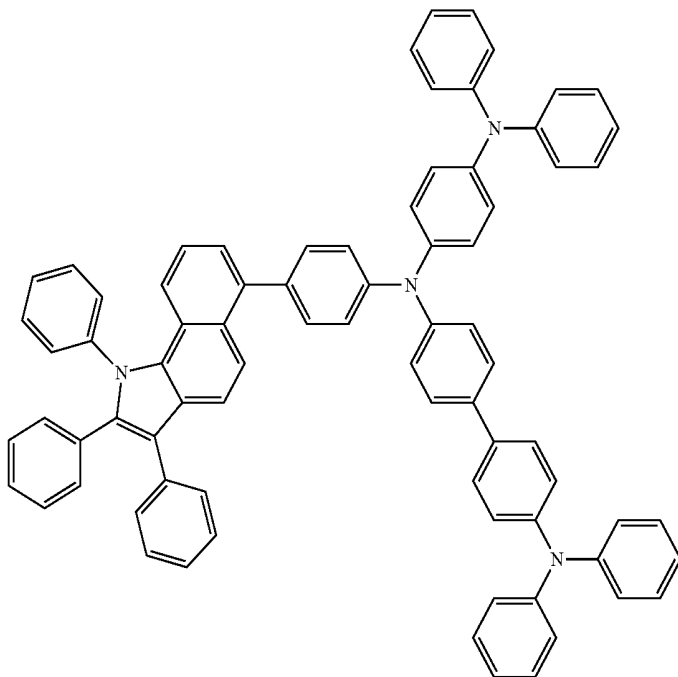

45

46

-continued

69

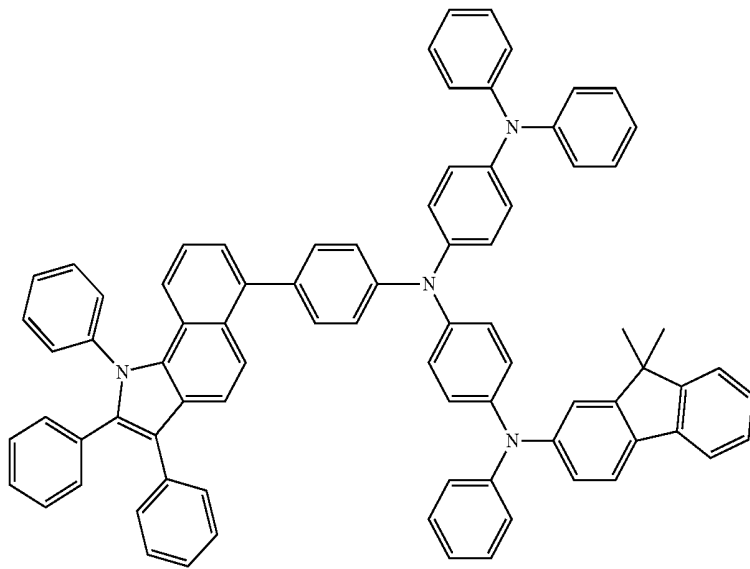

70

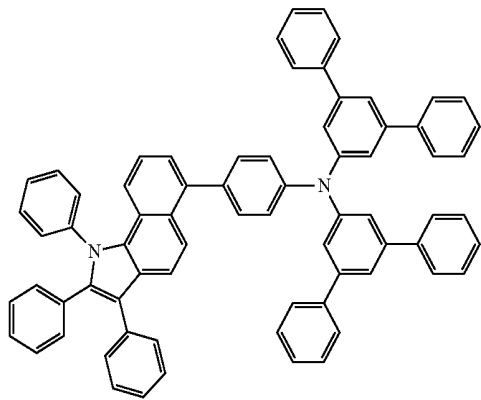

71

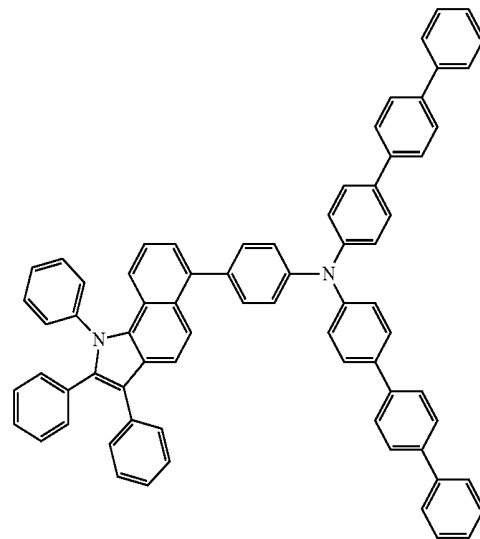

72

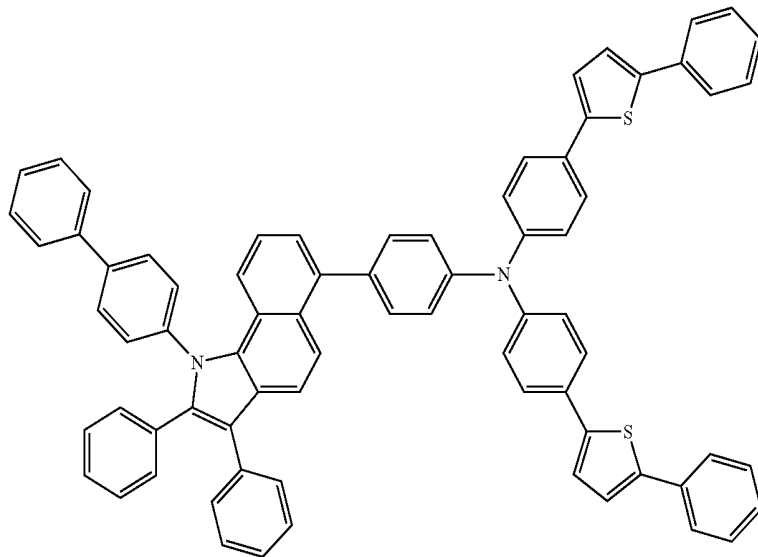

47

48

-continued

73

74

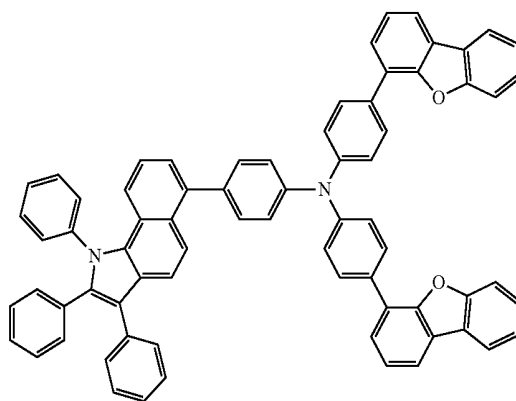
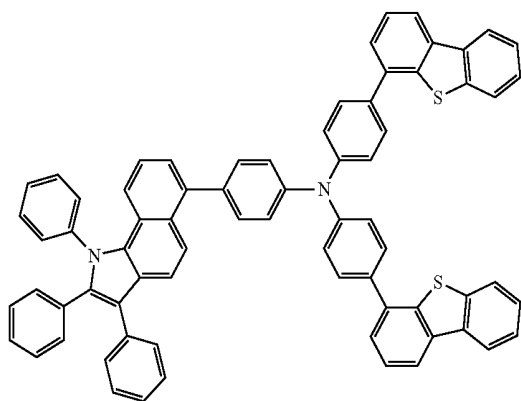

75

76

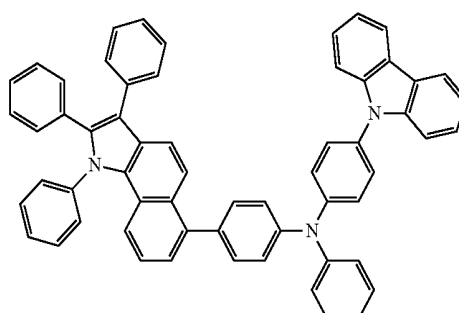
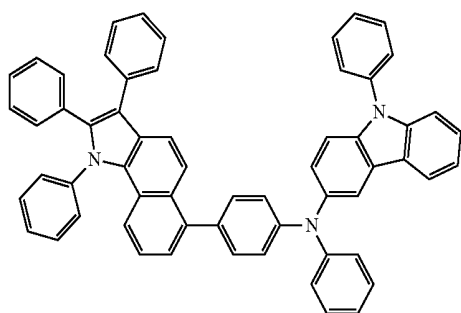

77

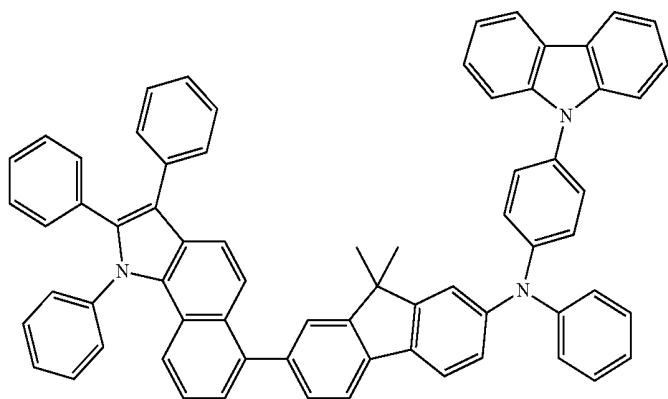

78

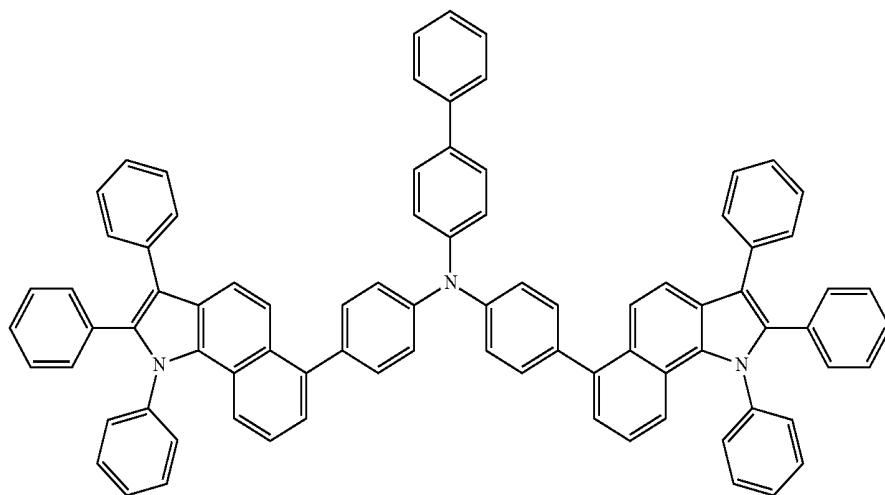

-continued

79

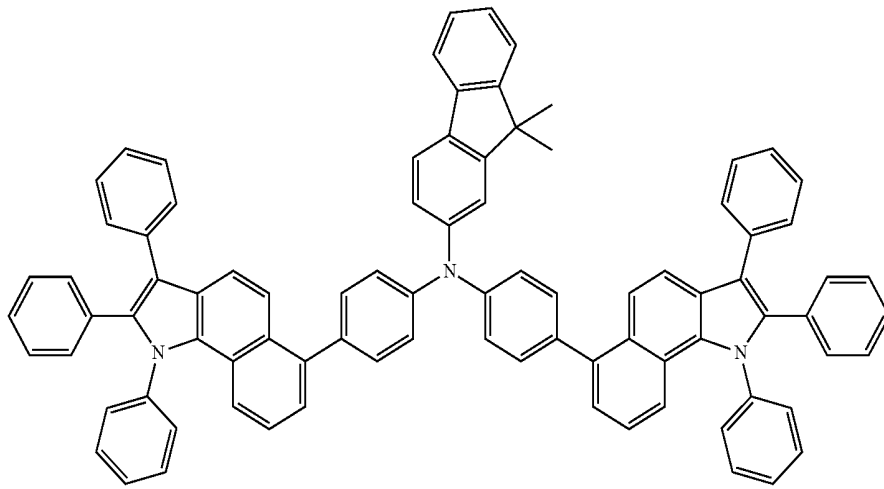

80

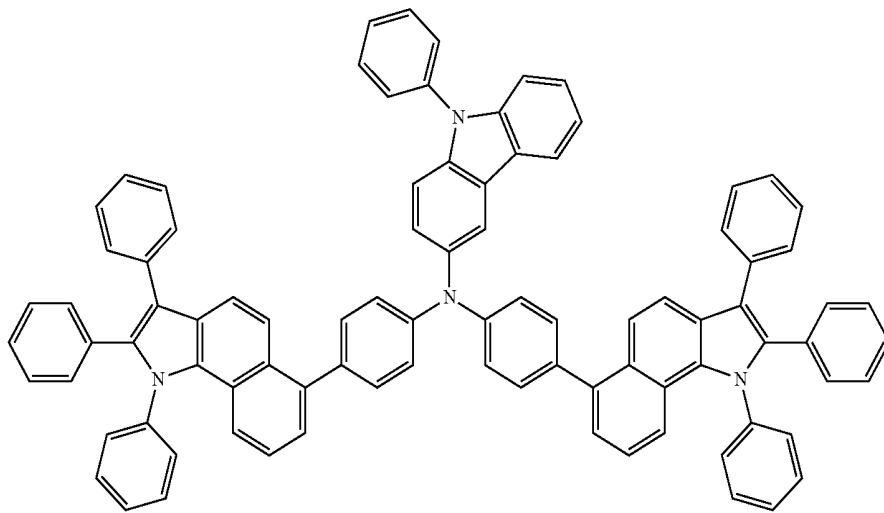

81

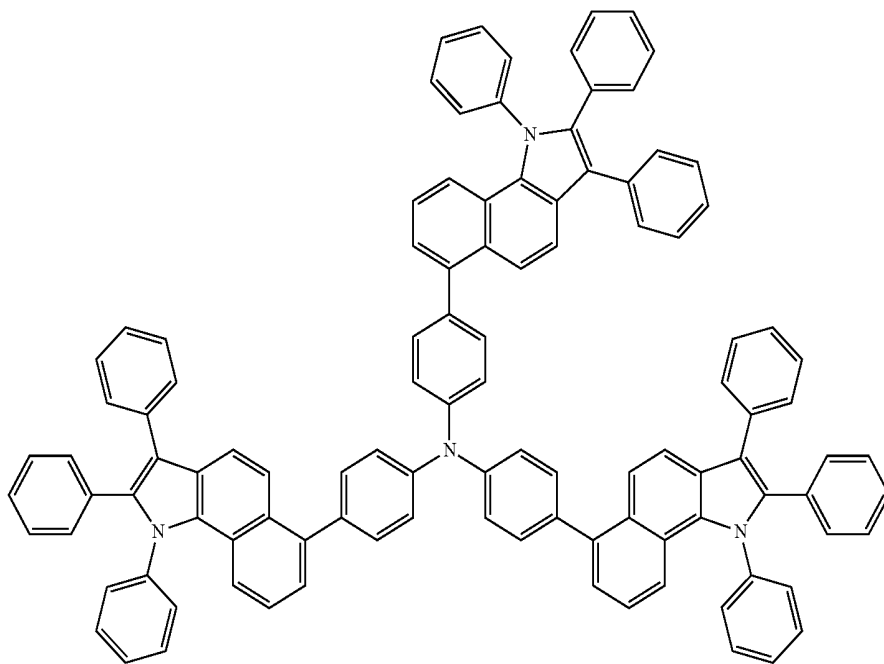

51

52

-continued

82

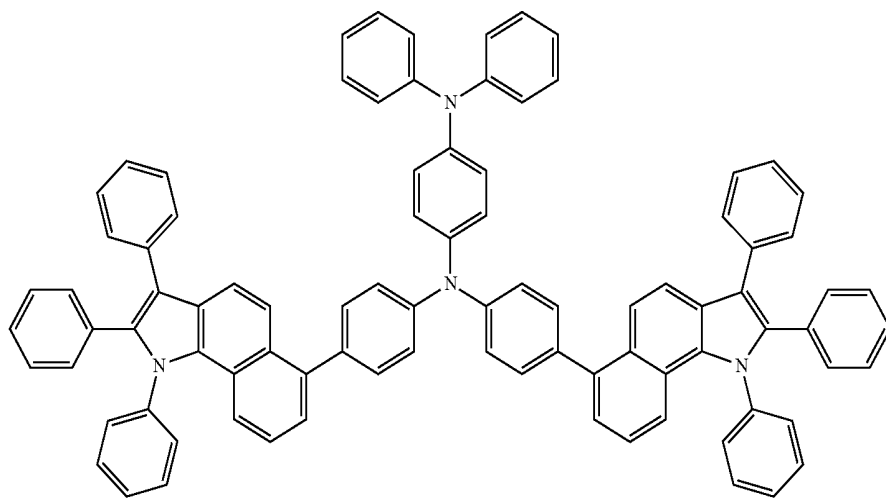

83

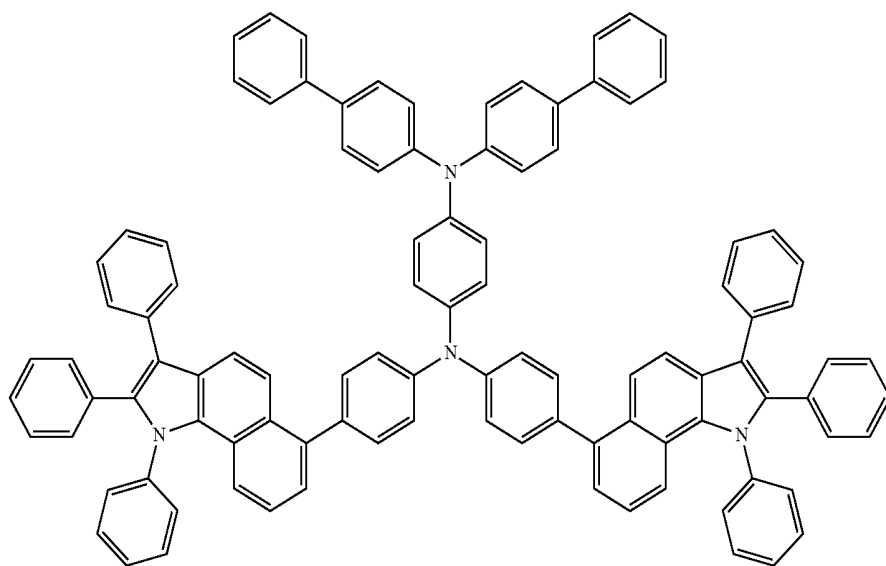

84

85

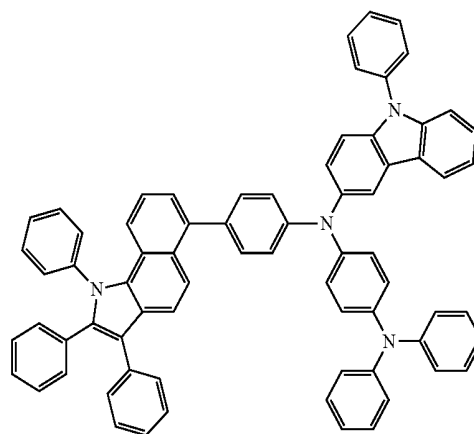
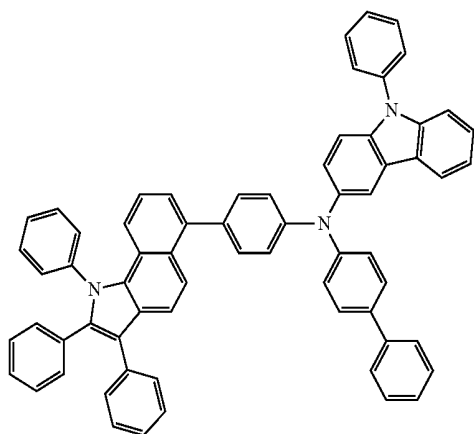

53

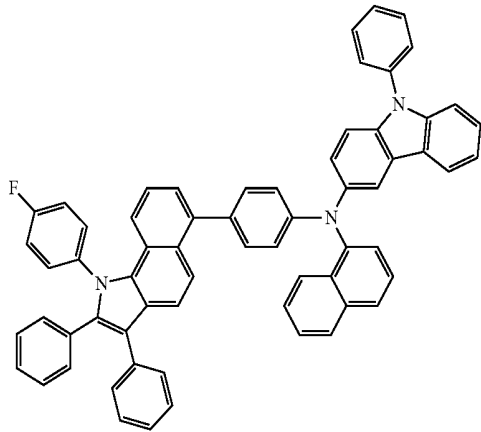

-continued  
86

54

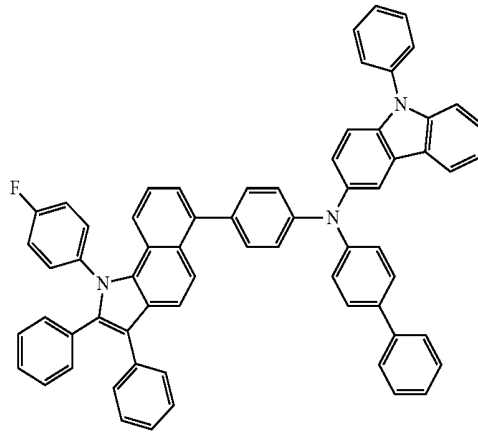

87

88

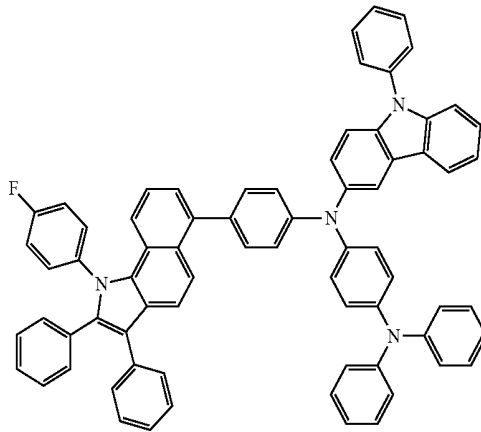

89

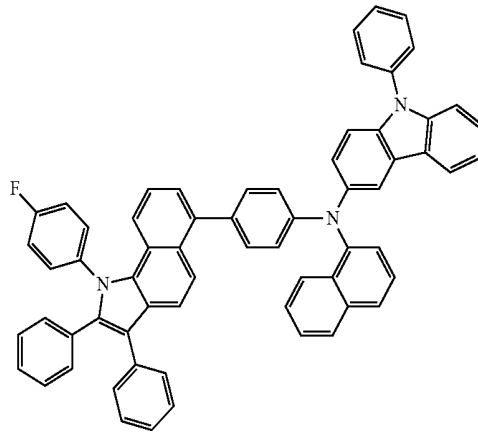

90

91

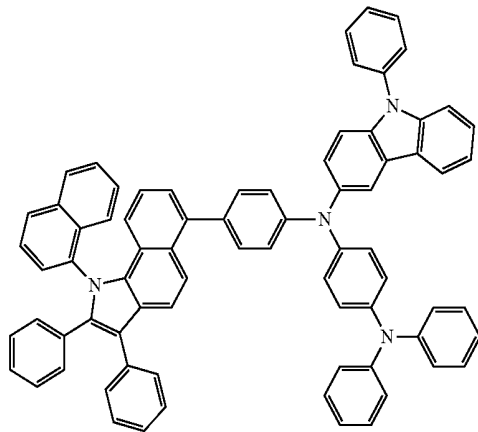
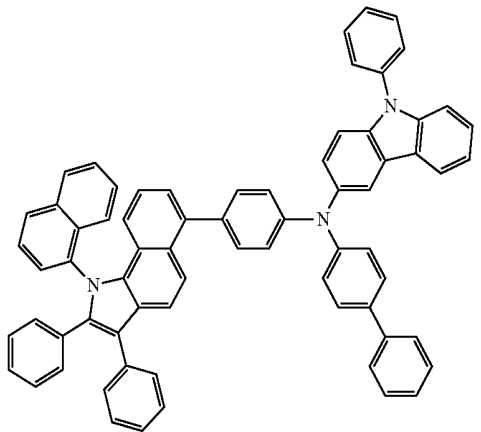

92

93

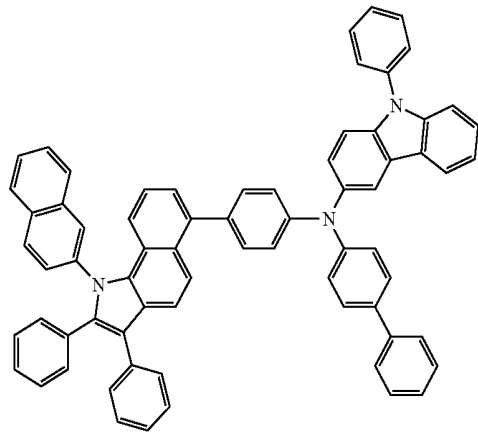
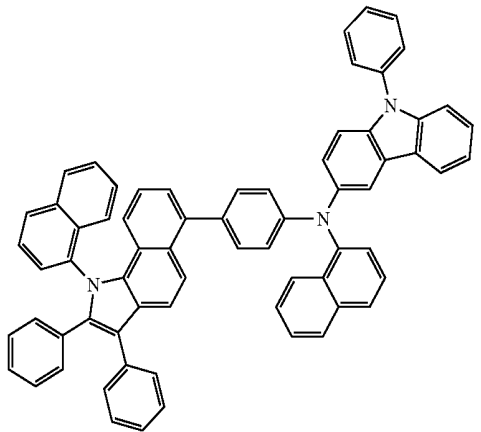

55

56

-continued

94

95

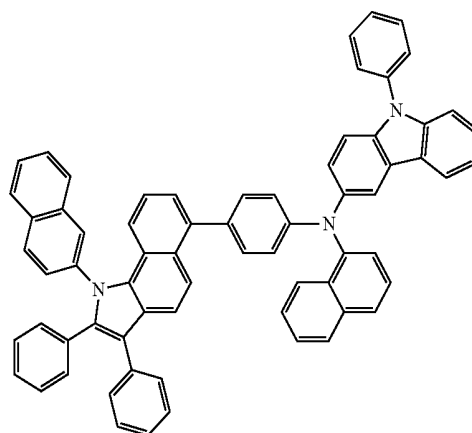
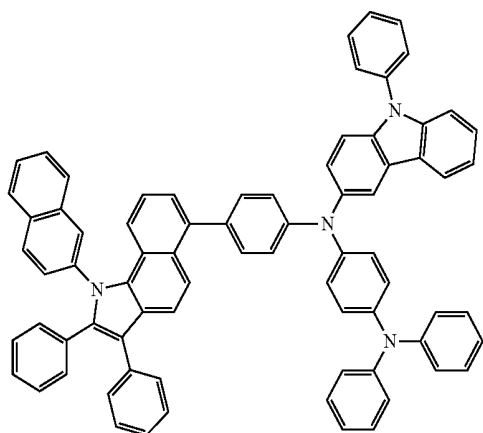

96

97

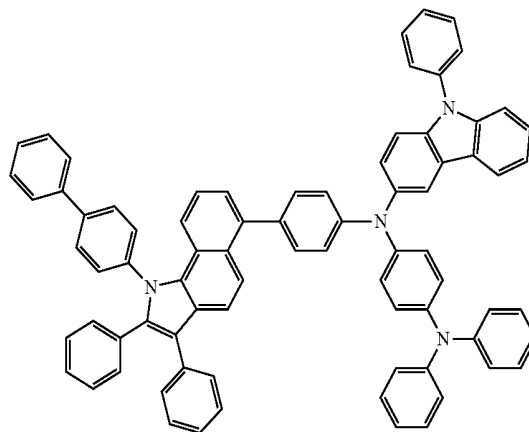
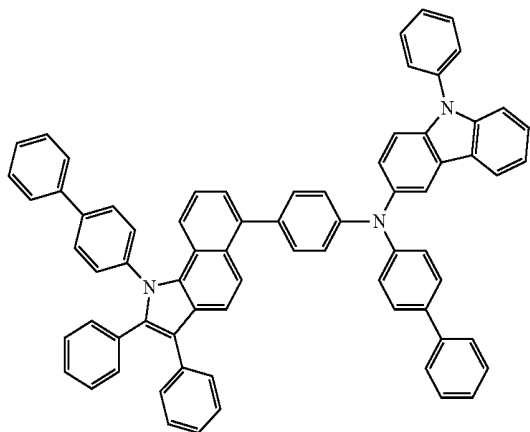

98

99

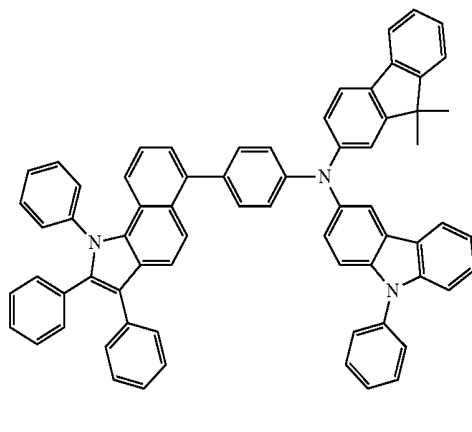
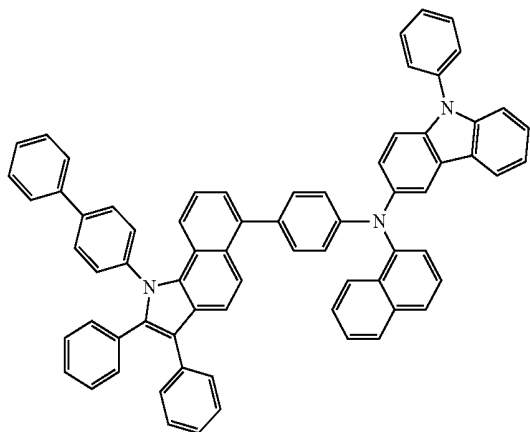

100

101

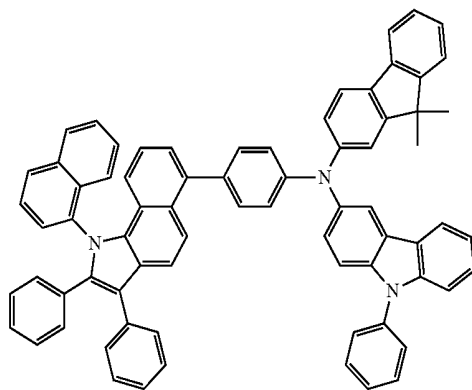
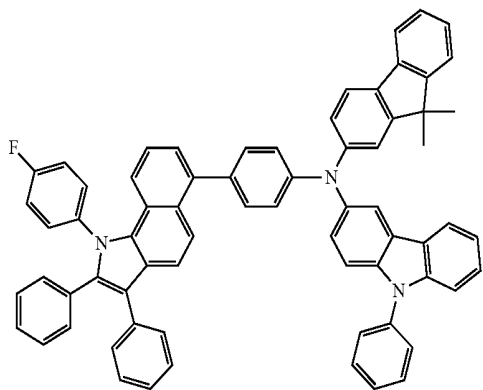

57

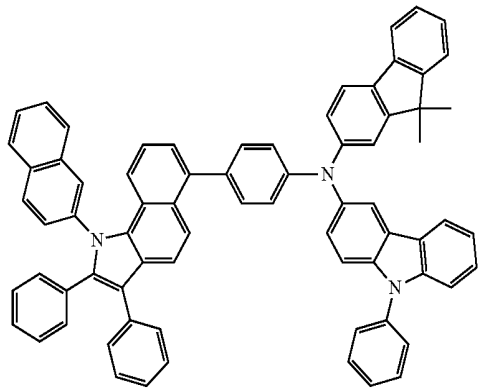

-continued  
102

58

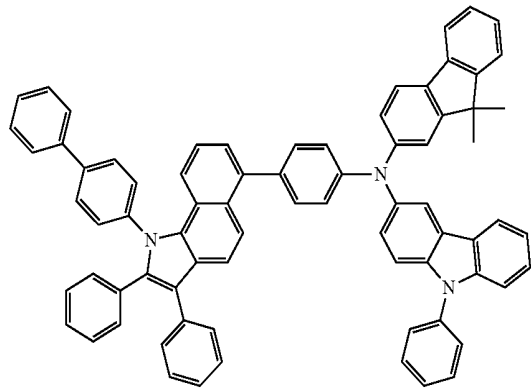

103

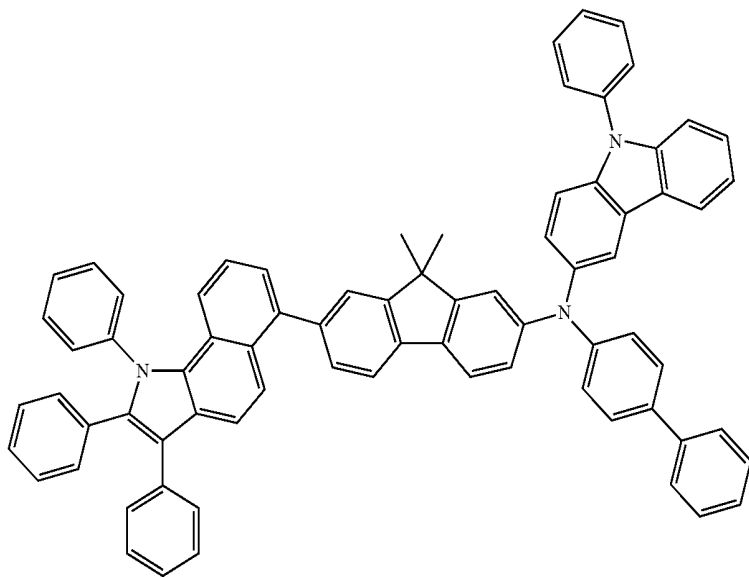

104

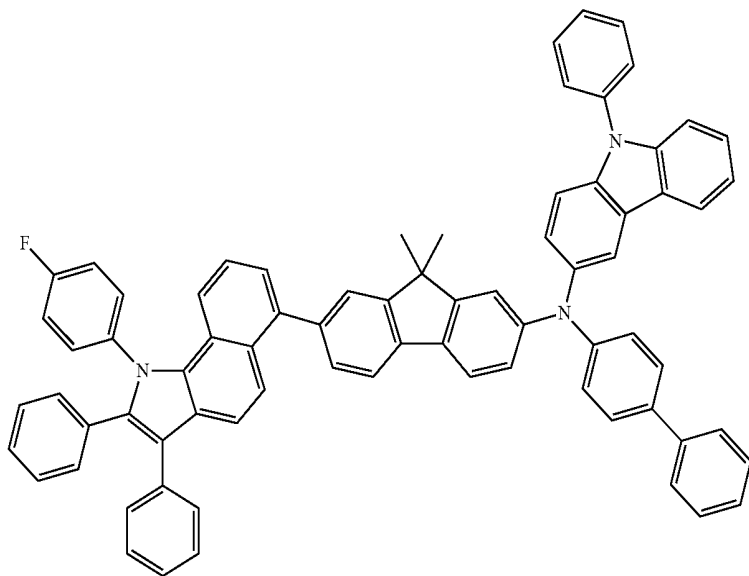

105

-continued

106

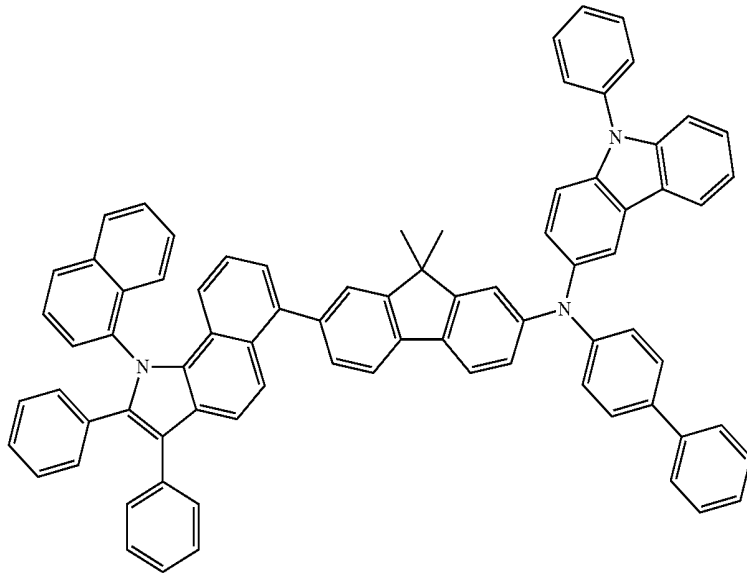

107

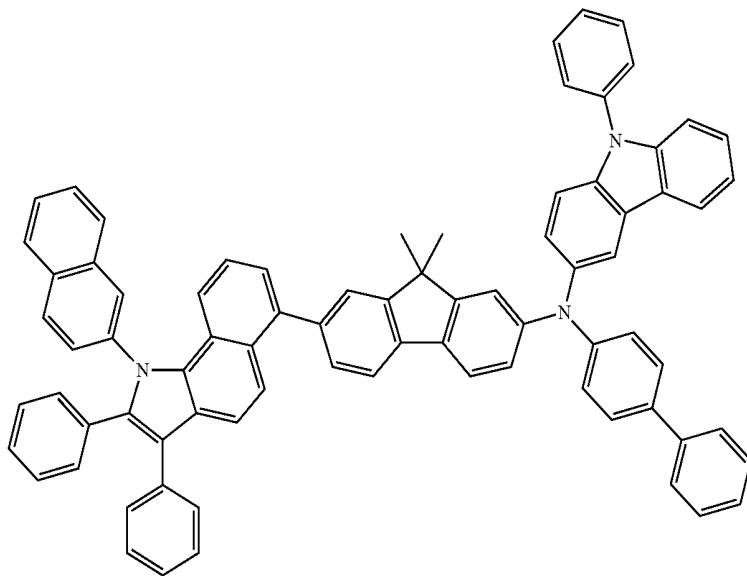

108

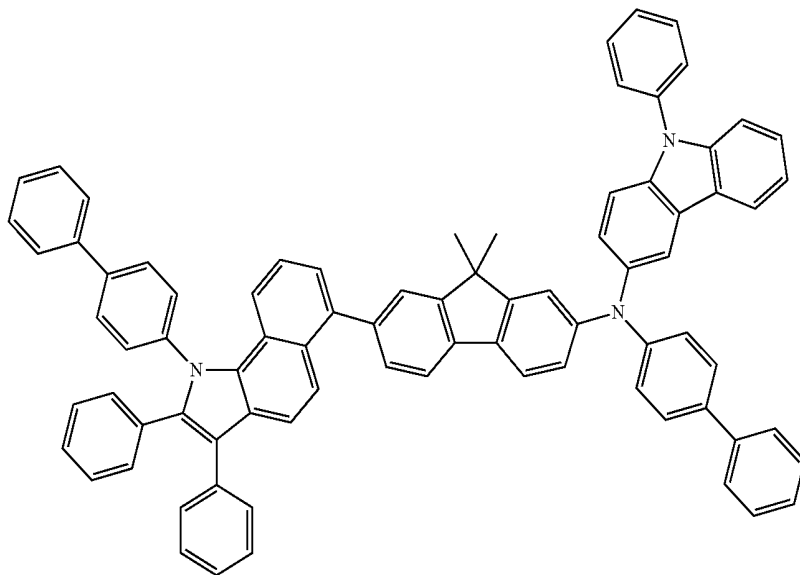

61

62

-continued

109

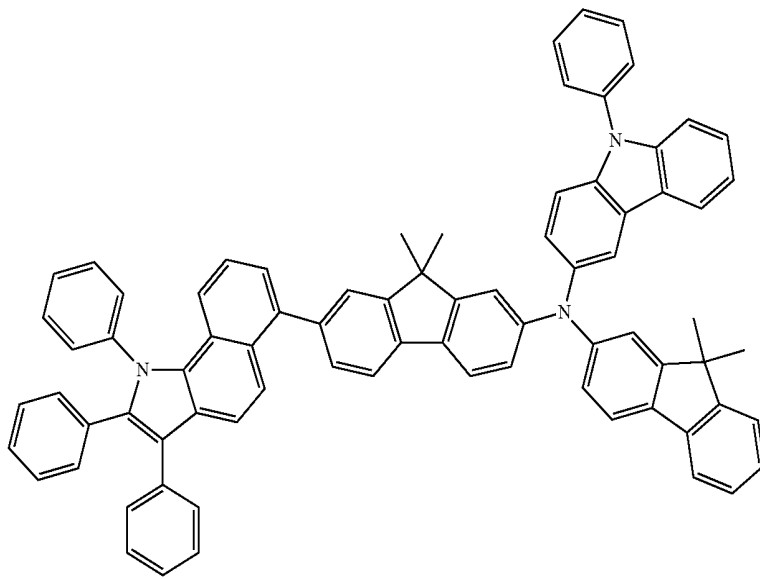

110

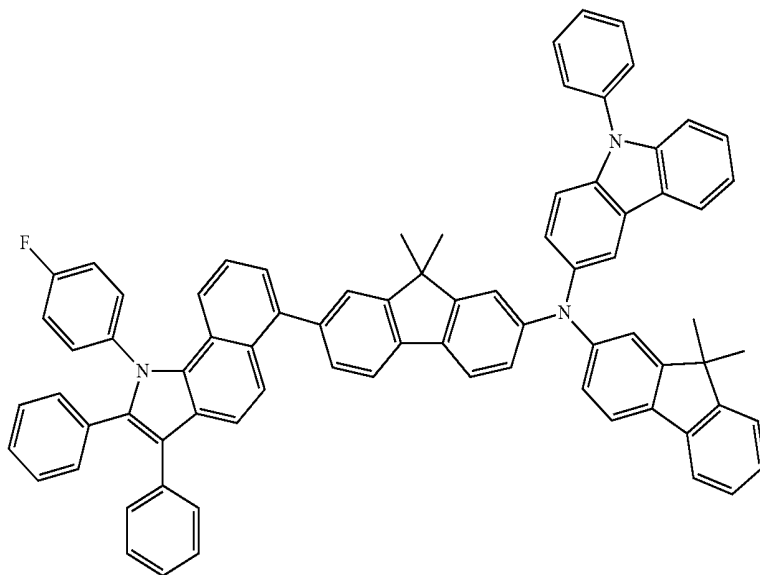

111

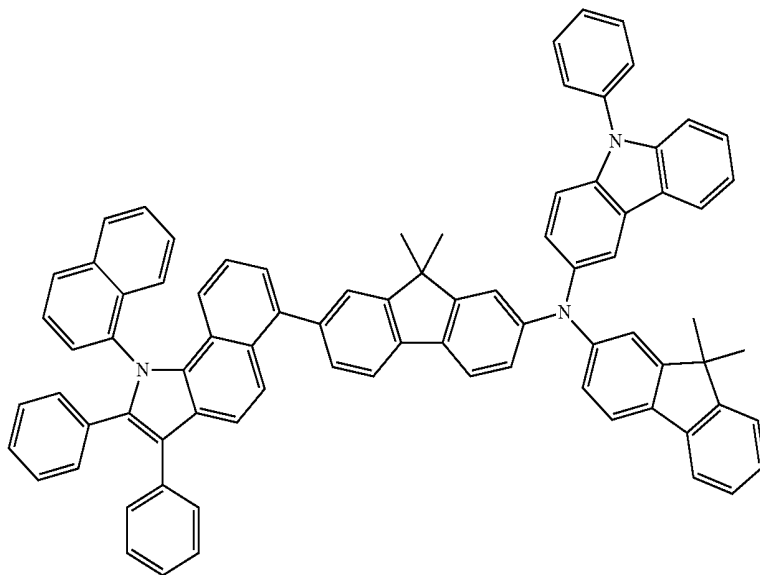

63

64

-continued

112

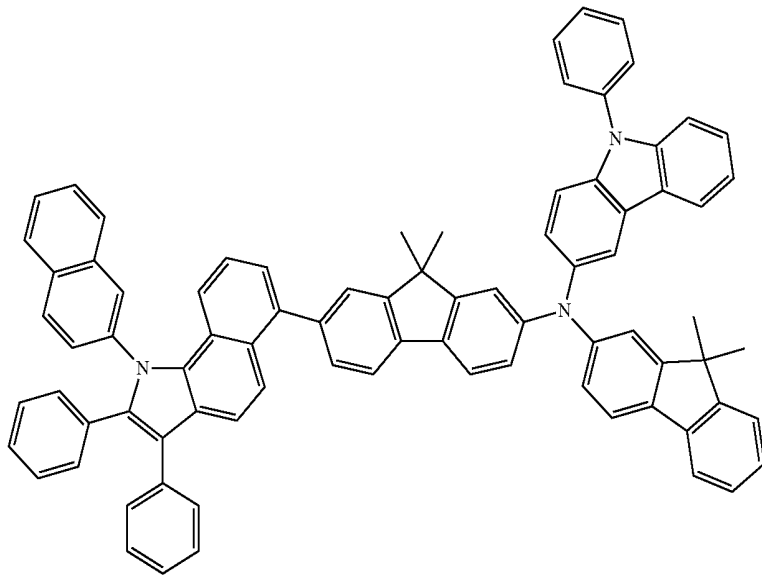

113

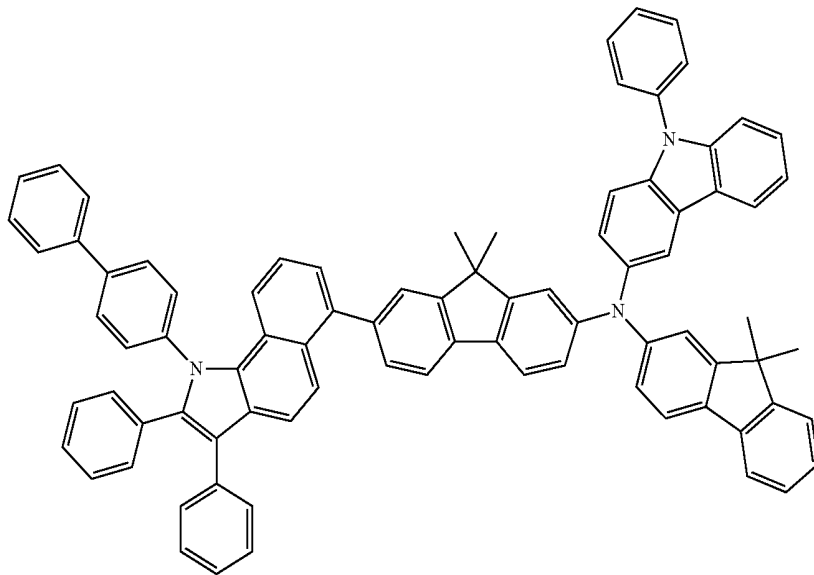

114

115

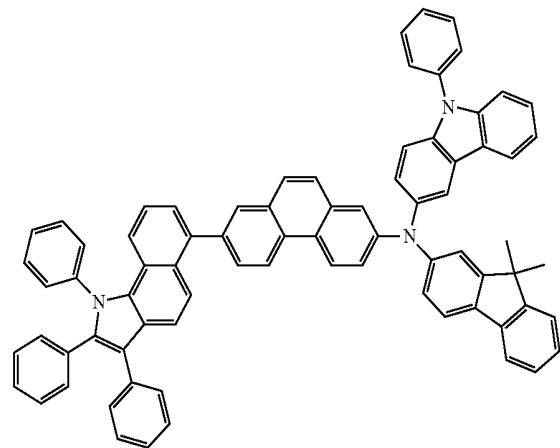
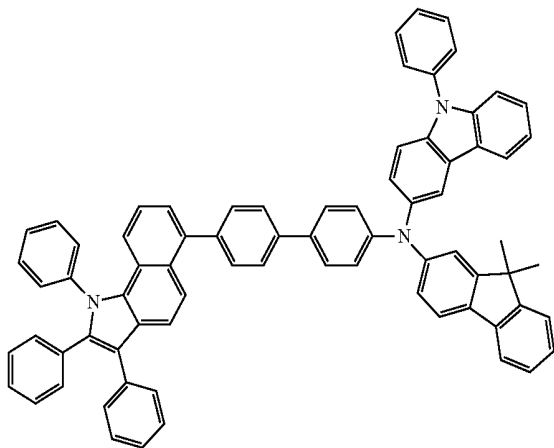

65

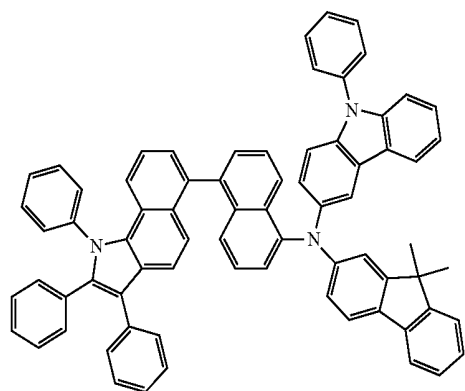

-continued  
116

66

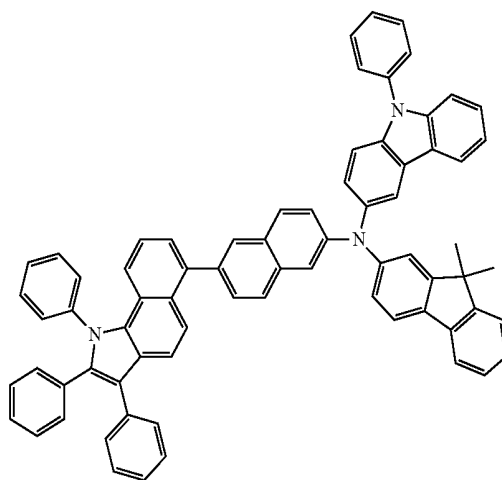

117

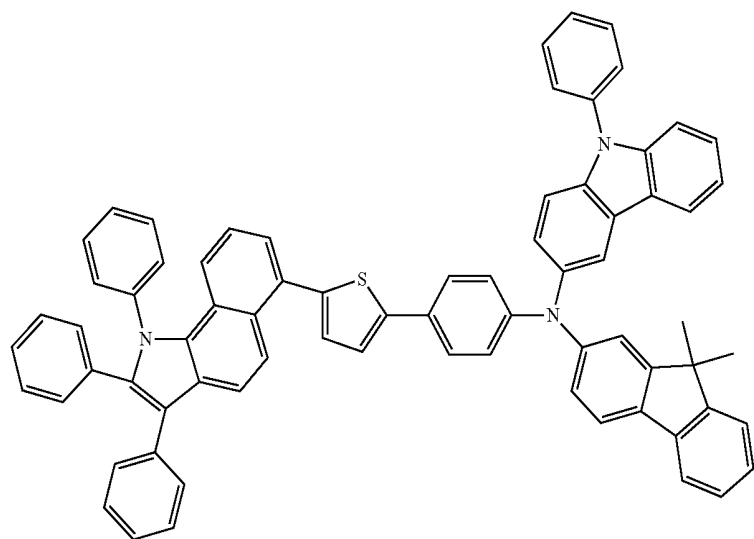

118

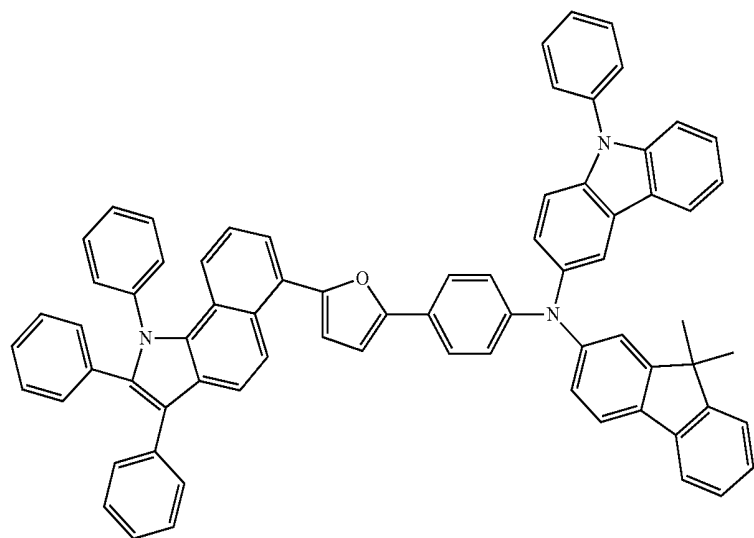

119

-continued

120

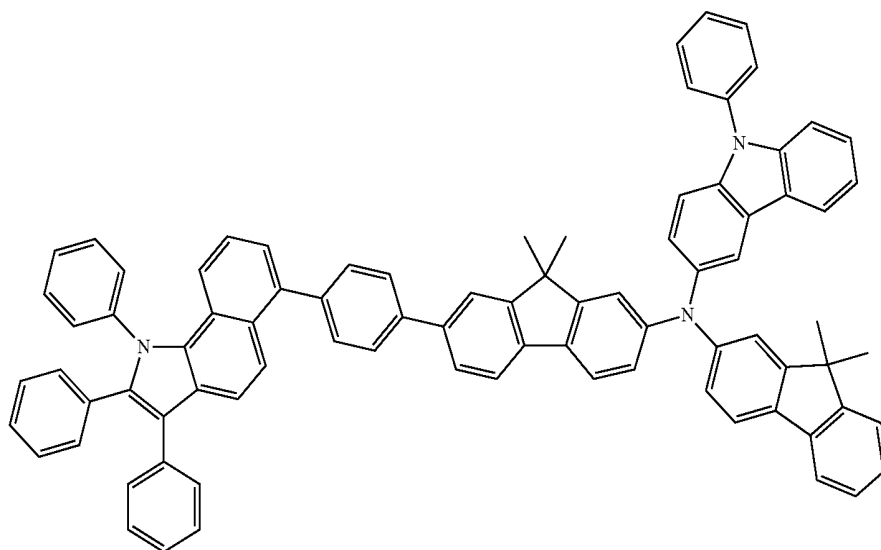

121

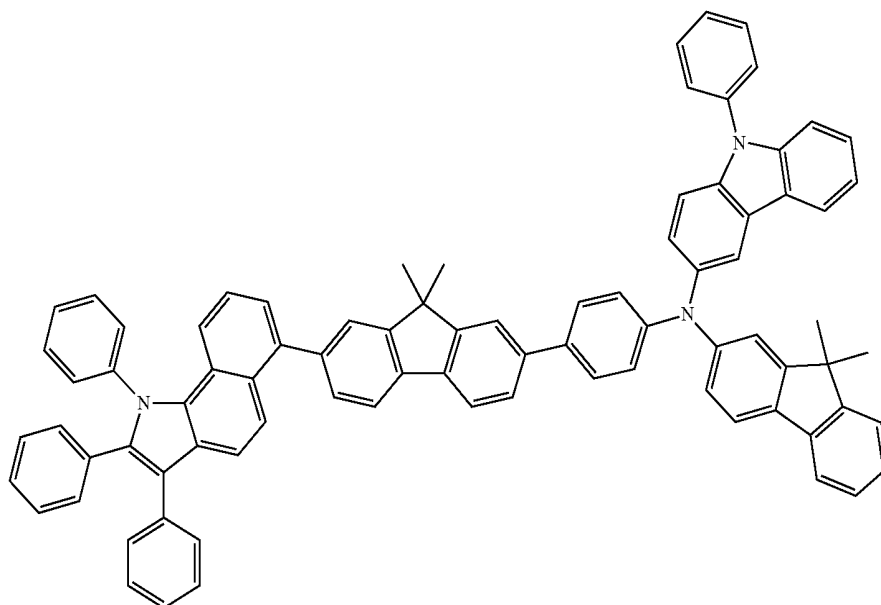

45

In some embodiments, for example, the heteroarylamine compound of Formula 1 is selected from Compound 1, Compound 2, Compound 8, Compound 29, Compound 32, Compound 52, Compound 58, and Compound 99.

According to other embodiments of the present invention, a method of synthesizing a heteroarylamine compound of Formula 1 is provided. Initially, benzophenone hydrazone, sodium butoxide, palladium diacetate and 2-dicyclohexylphosphino-2',4',6'-triisopropylbiphenyl are added to a heteroarylamine compound represented by Formula 7 below.

In Formula 7,  $X_1$ ,  $Ar_1$ , and  $Ar_2$  are as defined above in connection with Formula 1, and  $Y$  is a halogen atom selected from bromine, iodine, and chlorine.

50

Formula 8

55

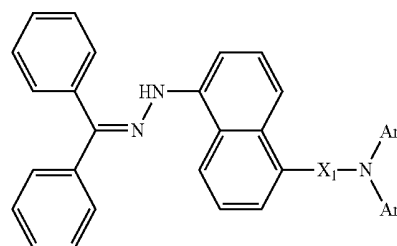

Formula 7 60

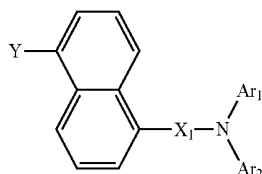

In Formula 8,  $X_1$ ,  $Ar_1$ , and  $Ar_2$  are as defined above in connection with Formula 1.

In the synthesis method, the amount of benzophenone hydrazone may be about 1.05 to about 1.2 moles based on 1 mole of the heteroarylamine compound of Formula 7. The

65

amount of sodium butoxide may be about 1.2 to about 1.5 moles based on 1 mole of the heteroarylamine compound of Formula 7. In addition, the amount of palladium diacetate may be about 0.02 to about 0.05 moles, and the amount of 2-dicyclohexylphosphino-2',4',6'-triisopropylbiphenyl may be

about 0.02 to about 0.05 moles, based on 1 mole of the heteroarylamine compound of Formula 7.

The heating may be performed at a temperature of about 80 to about 100° C. When the heating temperature is within this range, an high yield of the compound of Formula 8 may be

obtained.

Next, p-toluenesulfonic acid monohydrate, benzylphenylketone and a solvent are added to the compound of Formula 8, and the components are heated. When the reaction is completed, the reaction product is worked up to obtain the heteroarylamine compound of Formula 1. The heating for the reaction may be performed at a temperature of about 60 to about 100° C. When the heating temperature is within this range, a high yield of the heteroarylamine compound of Formula 1 may be obtained.

The amount of p-toluenesulfonic acid monohydrate may be about 1.5 to about 2.0 moles, and the amount of benzylphenylketone may be about 1.5 to about 2.0 moles, based on 1 mole of the compound of Formula 8.

According to other embodiments of the present invention, an organic light-emitting device includes a first electrode, a second electrode, and an organic layer between the first electrode and the second electrode. The organic layer includes at least one organic layer containing the heteroarylamine compound of Formula 1 described above. The heteroarylamine compound may be used exclusively or may be included in a mixture.

The at least one organic layer containing the heteroarylamine compound of Formula 1 may include a hole injection layer, a hole transport layer, or a single layer having both hole injection and hole transport capabilities. The at least one organic layer containing the heteroarylamine compound of Formula 1 may include an emission layer. The heteroarylamine compound of Formula 1 may be used as a host material for a blue, green, or red fluorescent or phosphorescent

material.

In some embodiments, for example, the at least one organic layer containing the heteroarylamine compound represented by Formula 1 may include a hole injection layer or a hole transport layer.

The organic layer may include a hole injection layer, a hole transport layer, and an emission layer, wherein the hole injection layer or the hole transport layer may contain the heteroarylamine compound of Formula 1, and the emission layer may contain an anthracene compound.

Alternatively, the organic layer may include a hole injection layer, a hole transport layer and an emission layer, wherein the hole injection layer or the hole transport layer may contain the heteroarylamine compound of Formula 1, and the emission layer may contain a C<sub>4</sub>-C<sub>60</sub> heteroaryl compound or a styryl compound.

The first electrode may be an anode, and the second electrode may be a cathode, but the reverse is also possible.

The organic light-emitting device described above may also include at least one layer selected from a hole injection layer, a hole transport layer, an electron blocking layer, an emission layer, a hole blocking layer, an electron transport layer and an electron injection layer. The organic layer may have a double-layered structure.

An organic light-emitting device according to embodiments of the present invention may have a first electrode/hole injection layer/emission layer/second electrode structure, a

first electrode/hole injection layer/hole transport layer/emission layer/electron transport layer/second electrode structure, or a first electrode/hole injection layer/hole transport layer/emission layer/electron transport layer/electron injection layer/second electrode structure. An organic light-emitting device according other embodiments may have a first electrode/single layer having both hole injection and hole transport capabilities/emission layer/electron transport layer/second electrode structure, or a first electrode/single layer having both hole injection and hole transport capabilities/emission layer/electron transport layer/electron injection layer/second electrode structure.

An organic light-emitting device according to embodiments of the present invention may have various structures, such as a top emission type organic light-emitting device structure or a bottom emission type organic light-emitting device structure.

According to embodiments of the present invention, a method of manufacturing an organic light-emitting device is provided. FIG. 1 illustrates the structure of an organic light-emitting device according to an embodiment of the present invention. Referring to FIG. 1, according to embodiments of the present invention, an organic light-emitting device includes a substrate, a first electrode (anode), a hole injection layer (HIL), a hole transport layer (HTL), an emission layer (EML), an electron transport layer (ETL), an electron injection layer (EIL), and a second electrode (cathode).

The first electrode is formed on the substrate by deposition or sputtering. The first electrode may be formed of a first electrode material having a high work function. The first electrode may be an anode or a cathode. The substrate may be any substrate conventionally used in organic light-emitting devices, and may be, for example, a glass substrate or a transparent plastic substrate having good mechanical strength, thermal stability, transparency, surface planarity, handling convenience, and water resistance. The first electrode material may include at least one material selected from indium tin oxide (ITO), indium zinc oxide (IZO), tin oxide (SnO<sub>2</sub>), zinc oxide (ZnO), aluminum (Al), silver (Ag), and magnesium (Mg), which have good conductivity, and may form a transparent or reflective electrode.

A HIL may be formed on the first electrode by vacuum deposition, spin coating, casting, Langmuir Blodgett (LB) deposition, or the like. When the HIL is formed by vacuum deposition, the vacuum deposition conditions may vary according to the compound used to form the HIL and the desired structure and thermal properties of the HIL to be formed. In general, however, the vacuum deposition may be performed at a deposition temperature of about 100° C. to about 500° C., under a pressure of about 10<sup>-8</sup> torr to about 10<sup>-3</sup> torr, at a deposition speed of about 0.01 to about 100 Å/sec, and to a layer thickness of about 10 Å to about 5 μm.

When the HIL is formed by spin coating, the coating conditions may vary according to the compound used to form the HIL and the desired structure and thermal properties of the HIL to be formed. In general, however, the coating speed may be about 2000 rpm to about 5000 rpm, and the temperature for heat treatment (performed to remove the solvent after coating) may be about 80° C. to about 200° C.

The HIL material may include the heteroarylamine compound of Formula 1 described above. Alternatively, any known HIL material may be used. Nonlimiting examples of HIL materials include phthalocyanine compounds (such as copper phthalocyanine), star-burst type amine derivatives (such as TCTA, 4,4',4''-tris(3-methylphenylphenylamino)triphenylamine (m-MTDATA), N,N'-di(1-naphthyl)-N,N'-diphenylbenzidine (NPB), TDATA, and 2-TNATA), polyaniline/dodecylbenzenesulfonic acid (Pani/DBSA), poly(3,4-ethylenedioxythiophene)/poly(4-styrenesulfonate) (PEDOT/PSS), polyaniline/camphor sulfonic acid (Pani/CSA), and (polyaniline)/poly(4-styrenesulfonate) (PANI/PSS).

71

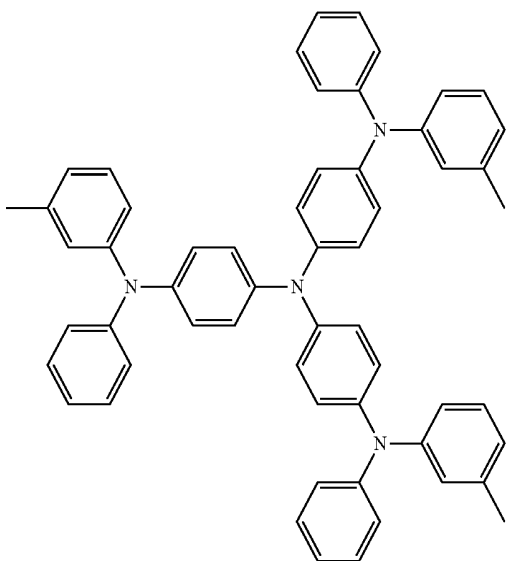

m-MTDATA

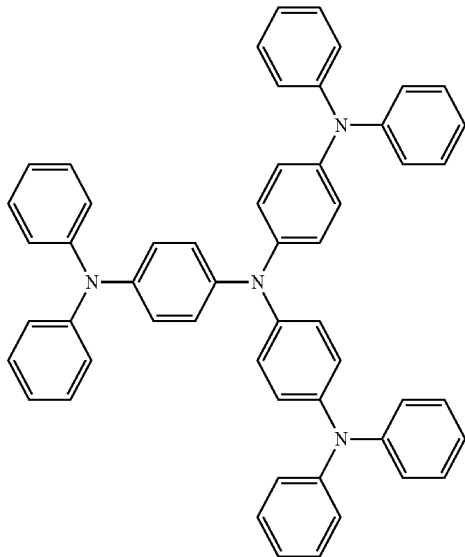

TDATA

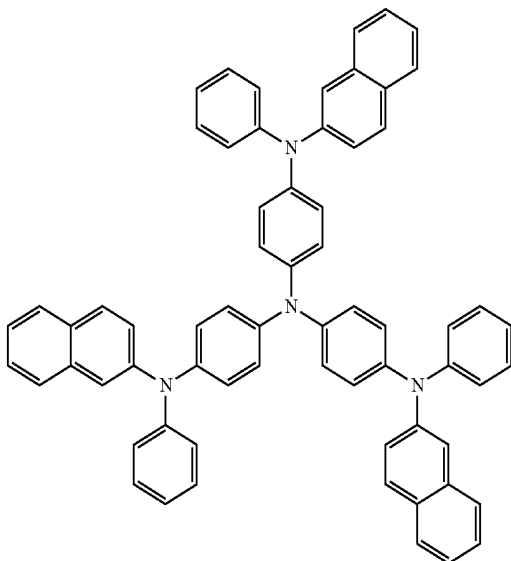

2-TNATA

72

-continued

5

10

15

20

25

30

35

40

45

50

55

60

65

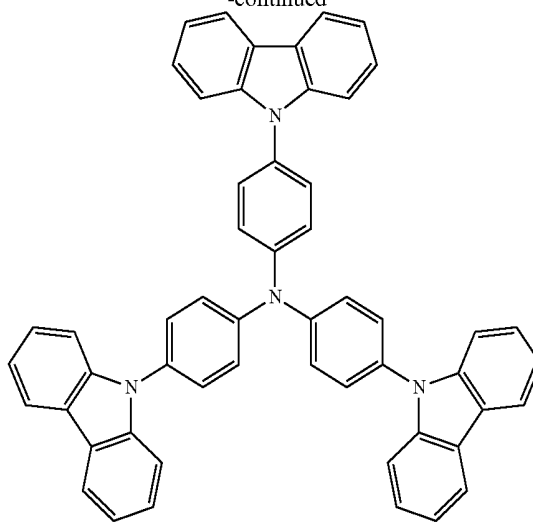

TCTA

The thickness of the HIL may be about 100 to about 10,000 Å. In some embodiments, for example, the thickness of the HIL is about 100 to about 1,000 Å. When the HIL has a thickness within these ranges, the HIL has good hole injection characteristics without increasing driving voltage.

A HTL may be formed on the HIL by vacuum deposition, spin coating, casting, LB deposition, or the like. When the HTL is formed by vacuum deposition or spin coating, the conditions for deposition and coating are similar to those for the formation of the HIL, although the conditions for the deposition and coating may vary according to the material used to form the HTL.

The HTL material may include the heteroarylamine compound of Formula 1 described above. Alternatively, when the heteroarylamine compound of Formula 1 is used as a material for the EML or HIL, the HTL may be formed of any suitable material for forming a HTL. Nonlimiting examples of suitable materials for the HTL include carbazole derivatives (such as N-phenylcarbazole and polyvinylcarbazole), and amine derivatives having condensed aromatic rings (such as 4,4'-bis[N-(1-naphthyl)-N-phenylamino]biphenyl (NPB), and N,N'-bis(3-methylphenyl)-N,N'-diphenyl-[1,1'-biphenyl]-4,4'-diamine (TPD)).

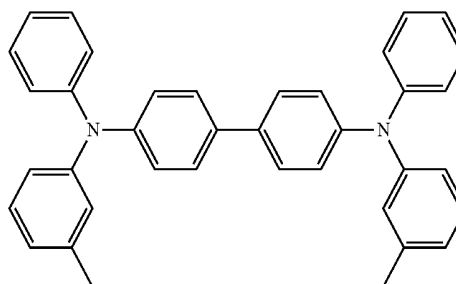

TPD

73

-continued

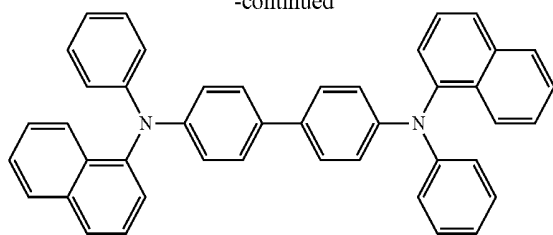

NPB

The thickness of the HTL may be about 50 to about 1,000 Å. In some embodiments, for example, the thickness of the HTL is about 100 to about 600 Å. When the HTL has a thickness within these ranges, the HTL has good hole transporting characteristics without substantially increasing driving voltage.

Optionally, an electron blocking layer may be formed on the HTL. The electron blocking layer blocks migration of electrons into the HTL. The electron blocking layer may include, for example, TATT represented by the following formula:

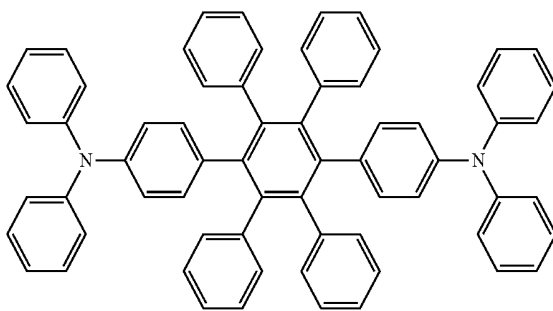

TATT

The thickness of the electron blocking layer may be about 50 to about 200 Å. When the electron blocking layer has a thickness within this range, the electron blocking layer has good electron blocking characteristics without substantially increasing driving voltage.

The EML is formed on the resultant structure. The EML may be formed by vacuum deposition, spin coating, casting, or LB deposition. When the EML is formed by vacuum deposition or spin coating, the conditions for deposition and coating are similar to those for the formation of the HIL, although the conditions for deposition and coating may vary according to the material used to form the EML.

The EML may include the heteroarylamine compound of Formula 1. The heteroarylamine compound of Formula 1 may be used as a host of the EML. Alternatively, when the heteroarylamine compound of Formula 1 is used to form the HIL or the HTL, the EML of the organic light-emitting device may be formed of any suitable light-emitting material for forming the EML of an organic light-emitting device. Non-limiting examples of suitable light-emitting materials for forming the EML include known hosts and dopants. Dopants used to form the EML may include either a fluorescent dopant or a phosphorescent dopant.

Nonlimiting examples of hosts include Alq<sub>3</sub>, 4,4'-N,N'-dicarbazole-biphenyl (CPB), poly(n-vinylcarbazole) (PVK), 9,10-di(naphthalene-2-yl) anthracene (ADN), distyrylarylene (DSA), arylamine compounds, anthracene compounds having symmetrical or asymmetrical structures,

74

styryl anthracene compounds, pyrene compounds having symmetrical or asymmetrical structures, spirofluorene compounds, and fluorene compounds.

Either a fluorescent dopant or a phosphorescent dopant may be used as a dopant for forming the EML. Nonlimiting examples of the fluorescent dopant include styryl compounds, arylamine or heteroarylamine compounds, styrylheteroarylamine compounds, and aminopyrene compounds. Nonlimiting examples of the phosphorescent dopant include Ir(PPy)<sub>3</sub> (PPy=phenylpyridine) (green), compound A represented by the following formula, F<sub>2</sub>Irpic, RD 61 (which is a red phosphorescent dopant available from UDC), and metal-complex compounds including iridium (Ir), ruthenium (Ru), palladium (Pd), platinum (Pt), osmium (Os), or rhenium (Re) as a core metal.

Compound A

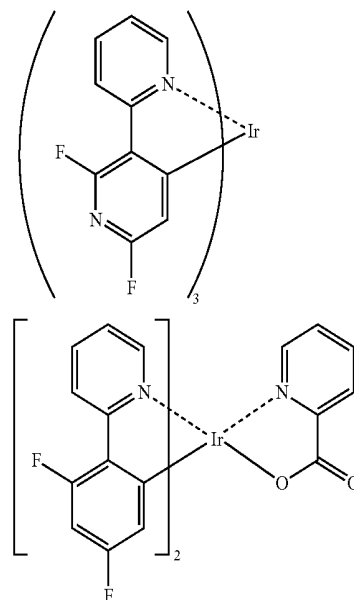
F<sub>2</sub>Irpic

Nonlimiting examples of red dopants include platinum(II) octaethylporphyrin (PtOEP), Ir(piq)<sub>3</sub>, Btp<sub>2</sub>Ir(acac), and DCJTb.

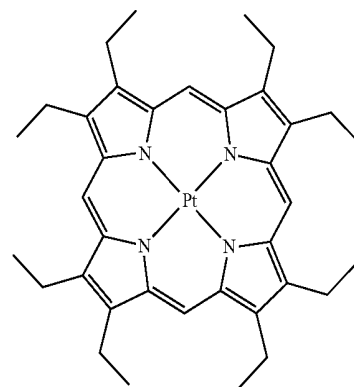

PtOEP

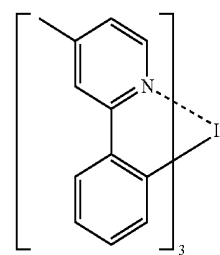
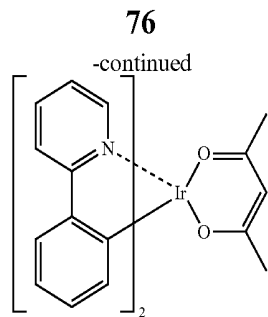
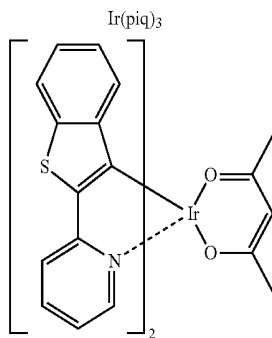
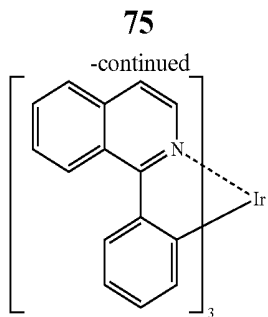

Nonlimiting examples of green dopants include Ir(ppy)<sub>3</sub> (where “ppy” denotes phenylpyridine), Ir(ppy)<sub>2</sub>(acac), Ir(mpyp)<sub>3</sub>, and C545T.

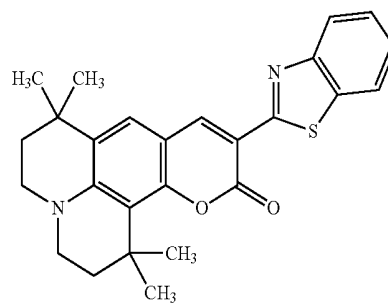
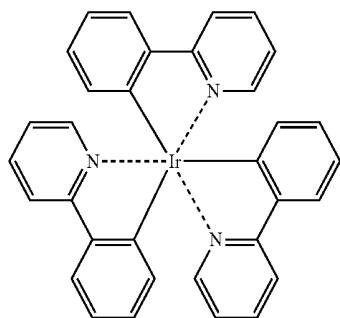

Nonlimiting examples of blue dopants include F<sub>2</sub>Irpic, (F<sub>2</sub>ppy)<sub>2</sub>Ir(tmd), Ir(dfppz)<sub>3</sub>, ter-fluorene, 4,4'-bis(4-diphenylaminostyryl)biphenyl (DPAVBi), and 2,5,8,11-tetra-t-butyl perylene (TBP).

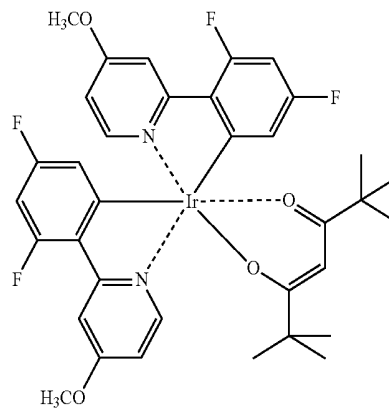
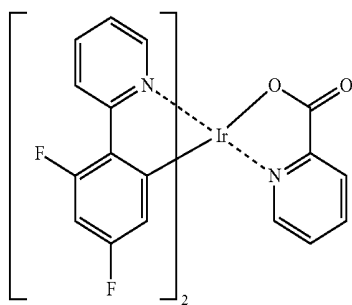

-continued

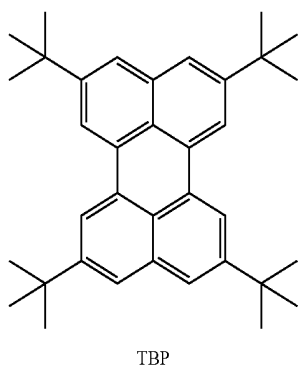
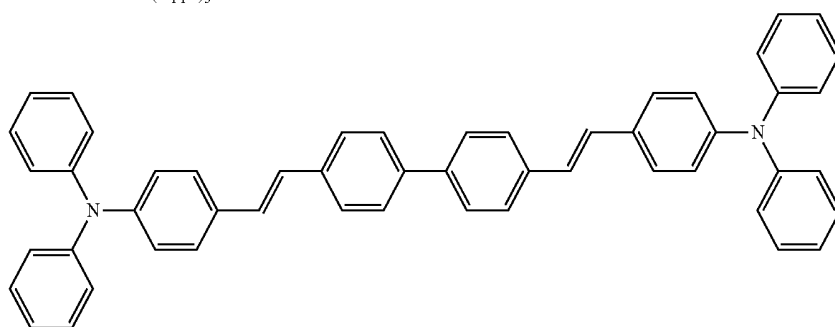
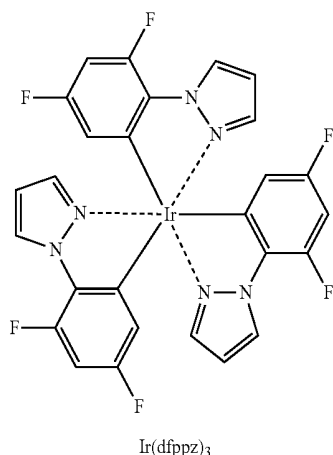

The amount of the dopant may be about 0.1 to about 20 parts by weight based on 100 parts by weight of the EML material, which is the total weight of the host and dopant. In some embodiments, for example, the amount of the dopant is about 0.5 to about 12 parts by weight based on 100 parts by weight of the EML material. When the amount of the dopant is within these ranges, concentration quenching may be substantially prevented.

The thickness of the EML may be about 100 to about 1000 Å. In some embodiments, for example, the thickness of the EML is about 200 to about 600 Å. When the thickness of the EML is within these ranges, good light emission characteristics may be obtained without increasing driving voltage.

When the EML includes a phosphorescent dopant, a hole blocking layer (HBL, not shown in FIG. 1) may be formed on the EML in order to prevent diffusion of triplet excitons or holes into the ETL. The HBL may be formed of any suitable material without limitation. Nonlimiting examples of suitable materials for the HBL include oxadiazole derivatives, triazole

derivatives, phenanthroline derivatives, bis(2-methyl-8-quinolato)-(p-phenylphenolato)-aluminum (Balq), bathocuproine (BCP), and tris(N-arylbenzimidazole) (TPBI).

The thickness of the HBL may be about 50 to about 1000 Å. In some embodiments, for example, the thickness of the HBL is about 100 to about 300 Å. When the thickness of the HBL is within these ranges, good hole-blocking characteristics may be obtained without increasing driving voltage.

The ETL may be formed on the HBL or EML by vacuum deposition, spin coating, or casting. When the ETL is formed by vacuum deposition or spin coating, the deposition and coating conditions may be similar to those for formation of the HIL, although the deposition and coating conditions may vary according to the compound used to form the ETL.

The ETL may be formed of any suitable material without limitation. Nonlimiting examples of suitable materials for the ETL include quinoline derivatives, for example, tris(8-quinolinolate)aluminum (Alq3), TAZ, and Balq.

79

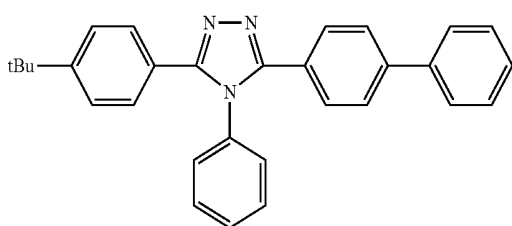

TAZ

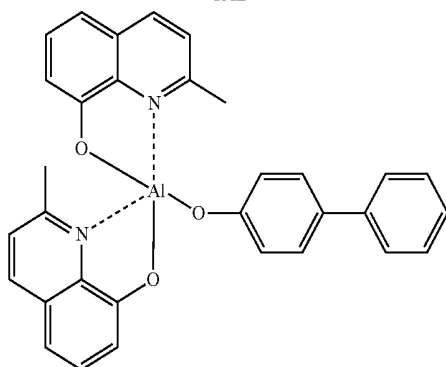

BAlq

The thickness of the ETL may be about 100 to about 1000 Å. In some embodiments, for example, the thickness of the ETL is about 100 to about 500 Å. When the ETL has a thickness within these ranges, the ETL may have good electron transport characteristics without substantially increasing driving voltage.

In addition, an electron injection layer (EIL) for facilitating the injection of electrons from the cathode may be formed on the ETL. Nonlimiting examples of materials for the EIL include BaF<sub>2</sub>, LiF, NaCl, CsF, Li<sub>2</sub>O, BaO, and Liq.

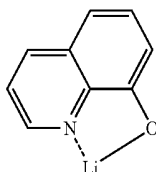

Liq

The deposition or coating conditions used to form the EIL may be similar to those used to form the HIL, although the deposition and coating conditions may vary according to the material used to form the EIL.

The thickness of the EIL may be about 1 to about 100 Å. In some embodiments, for example, the thickness of the EIL is about 5 to about 90 Å. When the EIL has a thickness within these ranges, the EIL may have good electron injection characteristics without substantially increasing driving voltage.

Finally, the second electrode may be formed on the EIL by vacuum deposition or sputtering. The second electrode may be a cathode or an anode. The material for forming the second electrode may be selected from metals, alloys, electrically conductive compounds, materials which have a low work function, and mixtures thereof. Nonlimiting examples of materials for the second electrode include lithium (Li), magnesium (Mg), aluminum (Al), aluminum-lithium (Al—Li), calcium (Ca), magnesium-indium (Mg—In), and magnesium-silver (Mg—Ag). In addition, in order to manufacture a

80

top-emission type organic light-emitting device, a transparent cathode formed of a transparent material such as ITO or IZO may be used as the second electrode.

The organic light-emitting device according to embodiments of the present invention may be included in various types of flat panel display devices, such as in passive matrix organic light-emitting display devices or active matrix organic light-emitting display devices. When the organic light-emitting device is included in an active matrix organic light-emitting display device including a thin-film transistor, the first electrode on the substrate may function as a pixel electrode, and be electrically connected to a source electrode or a drain electrode of the thin-film transistor. Moreover, the organic light-emitting device may also be included in a flat panel display device having a double-sided screen.

According to embodiments of the present invention, at least one layer of the organic light-emitting device may be formed of the heteroarylamine compound of Formula 1 and can be formed using a deposition method or a wet method of coating a solution of the heteroarylamine compound of Formula 1.

According to embodiments of the present invention, as shown in FIG. 2, a flat panel display includes a driving circuit 120 electrically connected to a pixel unit on a substrate 111. An insulating layer 112 such as a barrier layer and/or a buffer layer may be formed on the substrate 111 to planarize the surface of the substrate and to substantially prevent the diffusion of impurities and the penetration of external moisture and air.

A thin film transistor (TFT) as the driving circuit 120 is formed on the insulating layer 112. According to some embodiments, a top gate TFT may be used. However, it is understood that various other types of TFTs may also be used.

An activation layer 121 of the TFT includes a semiconductor material and is disposed on the insulating layer 112. A gate insulating layer 113 covers the activation layer 121. The activation layer 121 may include inorganic semiconductor materials (such as amorphous silicon or polysilicon), or organic semiconductor materials, and may have a source region, a drain region, and a channel region between the source region and the drain region.

A gate electrode 122 is disposed on the gate insulating layer 113, and an interlayer insulating layer 114 covers the gate electrode 122. Source and drain electrodes 123 are disposed on the interlayer insulating layer 114 and contact the activation layer through contact holes 124. A planarization layer 115 covers the source and drain electrodes 123. It is understood that the stack structure of the TFT is not limited to this constructions, but rather the TFT may have any suitable structure.

The first electrode 131 of the organic light emitting device is formed on the planarization layer 115, and is electrically connected to the source and drain electrodes 123 via a through hole 130. A pixel definition layer (not shown) is a thin inorganic layer formed on the first electrode 131. An opening is formed in the pixel definition layer to expose the first electrode 131 through the opening.

The following examples are presented for illustrative purposes only, and do not limit the scope of the present invention.

#### Synthesis Example 1

##### Synthesis of Intermediate 1

7 g (30 mmol) of 2-bromobiphenyl, 7.62 g (45 mmol) of aminobiphenyl, 4.3 g (45 mmol) of t-BuONa, 0.55 g (0.6 mmol) of Pd<sub>2</sub>(dba)<sub>3</sub>, and 0.12 g (0.6 mmol) of P(t-Bu)<sub>3</sub> were

## 81

dissolved in 100 mL of toluene and stirred at 90° C. for 3 hours. After the reaction was completed, the reaction product was cooled to room temperature and extracted three times with distilled water and 100 ml of diethylether. An organic layer was collected and dried using magnesium sulfate to evaporate the solvent. The residue was separated and purified using silica gel column chromatography to obtain 8.77 g (yield: 91%) of intermediate 1. This compound was identified using high-resolution mass spectrometry (HR-MS).  $C_{24}H_{19}N$  calc.: 321.1517; and found: 321.1519.

## Synthesis Example 2

## Synthesis of Intermediate 2

Intermediate 2 was synthesized with a yield of 87% in the same manner as Intermediate 1, except that 2-bromo-9,9-dimethylfluorene was used instead of 2-bromobiphenyl. This compound was identified using HR-MS.  $C_{27}H_{23}N$  calc.: 361.1830. found: 361.1834.

## Synthesis Example 3

## Synthesis of Intermediate 3

Intermediate 3 was synthesized with a yield of 85% in the same manner as Intermediate 2, except that 2-amino-9,9-dimethylfluorene was used instead of 4-aminobiphenyl. This compound was identified using HR-MS.  $C_{30}H_{27}N$  calc.: 401.2143; and found: 401.2147.

## Synthesis Example 4

## Synthesis of Intermediate 4

Intermediate 4 was synthesized with a yield of 90% in the same manner as Intermediate 3, except that 3-iodo-9-phenylcarbazole was used instead of 2-bromo-9,9-dimethylfluorene. This compound was identified using HR-MS.  $C_{33}H_{26}N_2$  calc.: 450.2096. found: 450.2100.

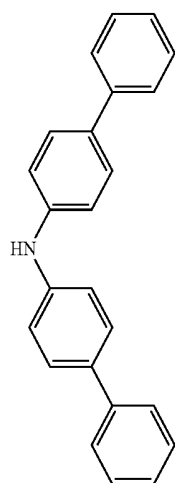

Intermediate 1

## 82

-continued

Intermediate 2

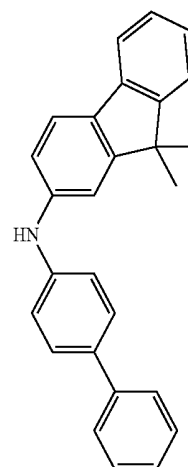

Intermediate 3

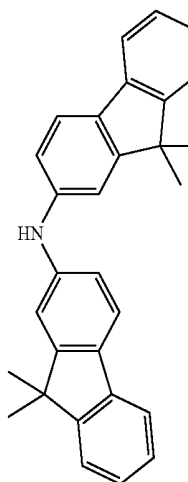

Intermediate 4

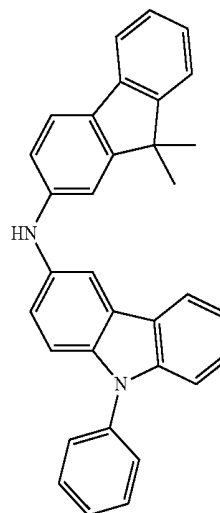

## Synthesis Example 5

## Synthesis of Intermediate 5

22.3 g (50 mmol) of 2,7-diiodo-9,9-dimethylfluorene, 3.21 g (10 mmol) of Intermediate 1, 2.88 g (30 mmol) of t-BuONa, 0.28 g (0.3 mmol) of  $Pd_2(dba)_3$ , and 0.6 g (0.3 mmol) of  $P(t-Bu)_3$  were dissolved in 100 ml of toluene and stirred at 90° C. for 3 hours. After the reaction was completed, the reaction

83

product was cooled to room temperature and extracted three times with distilled water and 100 ml of diethylether. An organic layer was collected and dried using magnesium sulfate to evaporate the solvent. The residue was separated and purified using silica gel column chromatography to obtain 3 g (yield: 47%) of Intermediate 5. This compound was identified using HR-MS.  $C_{39}H_{30}IN$  calc.: 639.1423; and found: 639.1427.

## Synthesis Example 6

## Synthesis of Intermediate 6

Intermediate 6 was synthesized with a yield of 52% in the same manner as Intermediate 5, except that 2,7-diiodophenanthrene (instead of 2,7-diiodo-9,9-dimethylfluorene) and N-phenyl-2-naphthylamine (instead of Intermediate 1) were used. This compound was identified using HR-MS.  $C_{30}H_{20}IN$  calc.: 521.0640. found: 521.0644.

## Synthesis Example 7

## Synthesis of Intermediate 7

Intermediate 7 was synthesized with a yield of 64% in the same manner as Intermediate 5, except that 1-bromo-4-iodobenzene (instead of 2,7-diiodo-9,9-dimethylfluorene) was reacted with 1-naphthyl-phenylamine. This compound was identified using HR-MS.  $C_{22}H_{16}BrN$  calc.: 373.0466. found: 373.0470.

## Synthesis Example 8

## Synthesis of Intermediate 8

Intermediate 8 was synthesized with a yield of 65% in the same manner as Intermediate 5, except that 1-bromo-4-iodobenzene was used instead of 2,7-diiodo-9,9-dimethylfluorene. This compound was identified using HR-MS.  $C_{30}H_{22}BrN$  calc.: 475.0936. found: 475.0940.

## Synthesis Example 9

## Synthesis of Intermediate 9

Intermediate 9 was synthesized with a yield of 62% in the same manner as Intermediate 5, except that 1-bromo-4-iodobenzene (instead of 2,7-diiodo-9,9-dimethylfluorene) was reacted with Intermediate 2 (instead of Intermediate 1). This compound was identified using HR-MS.  $C_{33}H_{26}BrN$  calc.: 515.1249. found: 515.1253.

## Synthesis Example 10

## Synthesis of Intermediate 10

Intermediate 10 was synthesized with a yield of 67% in the same manner as Intermediate 5, except that 1-bromo-4-iodobenzene (instead of 2,7-diiodo-9,9-dimethylfluorene) was reacted with Intermediate 3 (instead of Intermediate 1). This compound was identified using HR-MS.  $C_{36}H_{30}BrN$  calc.: 555.1562. found: 555.1566.

## Synthesis Example 11

## Synthesis of Intermediate 11

Intermediate 11 was synthesized with a yield of 65% in the same manner as Intermediate 5, except that 1-bromo-4-iodo-

84

benzene (instead of 2,7-diiodo-9,9-dimethylfluorene) was reacted with Intermediate 4 (instead of Intermediate 1). This compound was identified using HR-MS.  $C_{39}H_{29}BrN_2$  calc.: 604.1514. found: 604.1518.

Intermediate 5

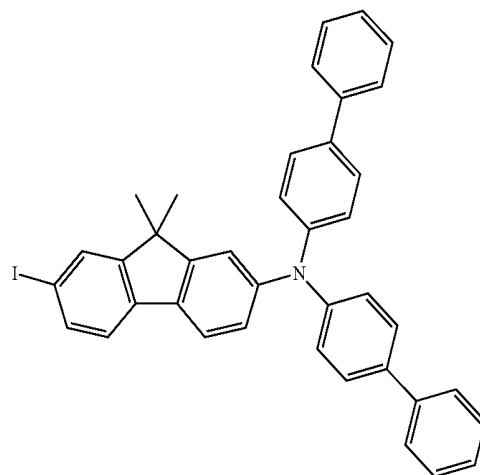

Intermediate 6

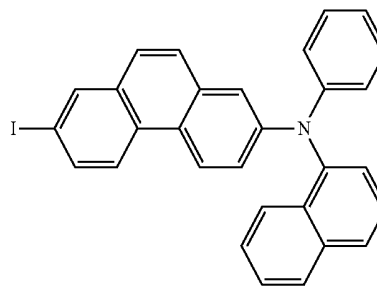

Intermediate 7

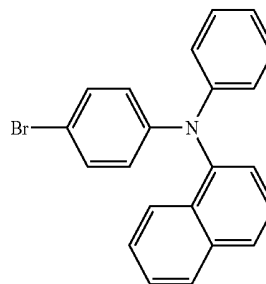

Intermediate 8

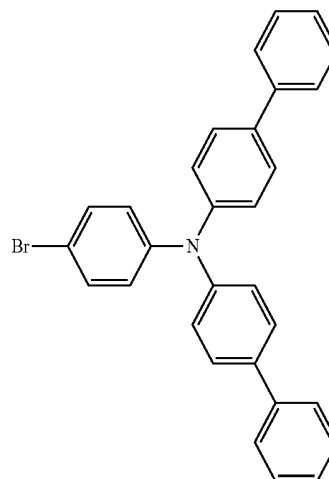

85

-continued

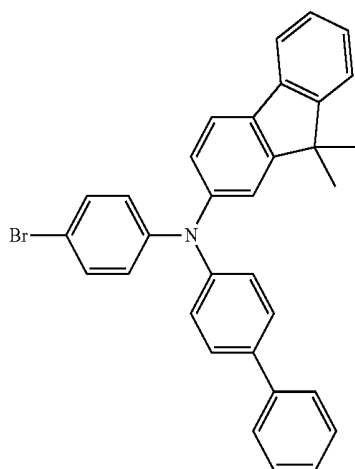

Intermediate 9

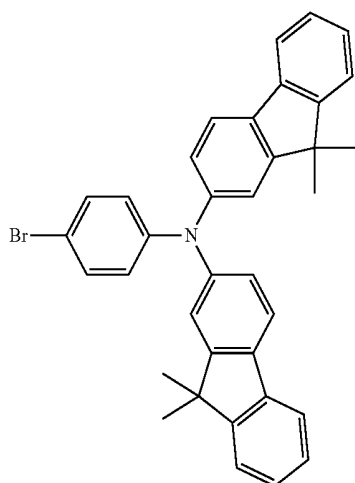

Intermediate 10

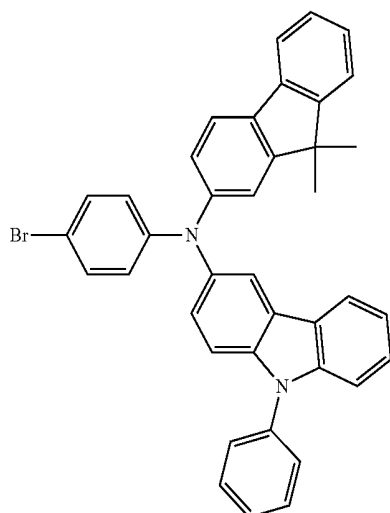

Intermediate 11

## Synthesis Example 12

## Synthesis of Intermediate 12

5.01 g (20 mmol) of 5-bromo-1-naphthylboronic acid, 11.22 g (30 mmol) of Intermediate 7, 1.15 g (1 mmol) of Pd(PPh<sub>3</sub>)<sub>4</sub>, and 1.6 g (40 mmol) of NaOH were dissolved in

86

60 ml of a mixed solution THF/H<sub>2</sub>O (2:1), and stirred at 80° C. for 3 hours. After the reaction was completed, the reaction product was cooled to room temperature and extracted three times with distilled water and 100 ml of diethylether. An organic layer was collected and dried using magnesium sulfate to evaporate the solvent. The residue was separated and purified using silica gel column chromatography to obtain 6.51 g (yield: 65%) of Intermediate 12. This compound was identified using HR-MS. C<sub>32</sub>H<sub>22</sub>BrN calc.: 499.0936. found: 499.0940.

## Synthesis Example 13

## Synthesis of Intermediate 13

Intermediate 13 was synthesized with a yield of 67% in the same manner as Intermediate 12, except that Intermediate 8 was used instead of Intermediate 7. This compound was identified using HR-MS. C<sub>40</sub>H<sub>28</sub>BrN calc.: 601.1405. found: 601.1409.

## Synthesis Example 14

## Synthesis of Intermediate 14

Intermediate 14 was synthesized with a yield of 63% in the same manner as Intermediate 12, except that Intermediate 9 was used instead of Intermediate 7. This compound was identified using HR-MS. C<sub>43</sub>H<sub>32</sub>BrN calc.: 641.1718. found: 641.1722.

## Synthesis Example 15

## Synthesis of Intermediate 15

Intermediate 15 was synthesized with a yield of 67% in the same manner as Intermediate 12, except that Intermediate 5 was used instead of Intermediate 7. This compound was identified using HR-MS. C<sub>49</sub>H<sub>36</sub>BrN calc.: 717.2031. found: 717.2035.

## Synthesis Example 16

## Synthesis of Intermediate 16

Intermediate 16 was synthesized with a yield of 70% in the same manner as Intermediate 12, except that Intermediate 6 was used instead of Intermediate 7. This compound was identified using HR-MS. C<sub>40</sub>H<sub>26</sub>BrN calc.: 599.1249. found: 599.1253.

## Synthesis Example 17

## Synthesis of Intermediate 17

Intermediate 17 was synthesized with a yield of 65% in the same manner as Intermediate 12, except that Intermediate 10 was used instead of Intermediate 7. This compound was identified using HR-MS. C<sub>46</sub>H<sub>36</sub>BrN calc.: 681.2031. found: 681.2035.

## Synthesis Example 18

## Synthesis of Intermediate 18

Intermediate 18 was synthesized with a yield of 70% in the same manner as Intermediate 12, except that Intermediate 11 was used instead of Intermediate 7. This compound was identified using HR-MS. C<sub>49</sub>H<sub>35</sub>BrN<sub>2</sub> calc.: 730.1984. found: 730.1988.

87

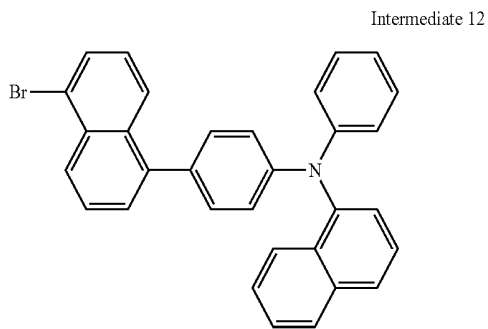

88

-continued

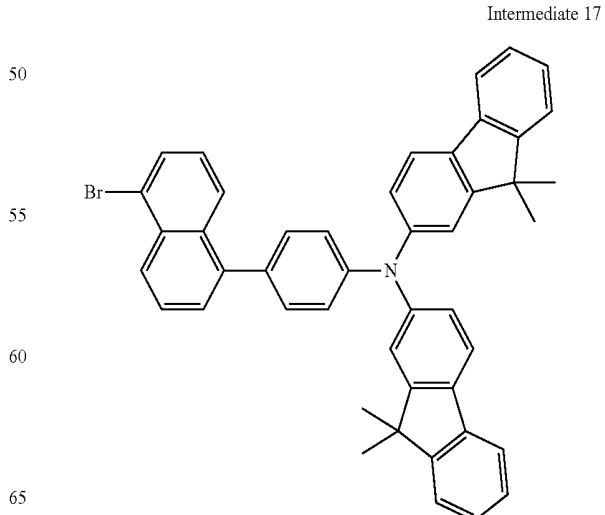
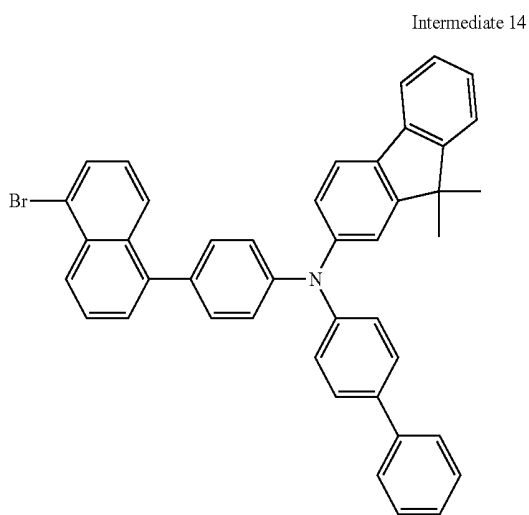
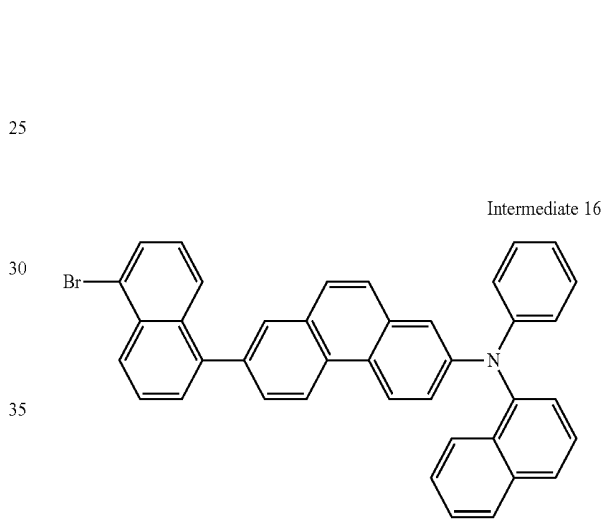
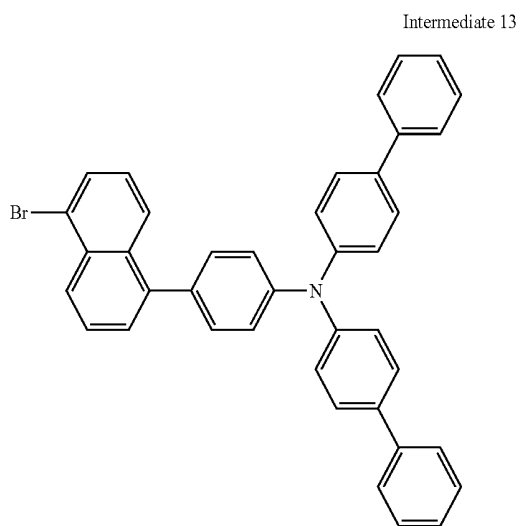
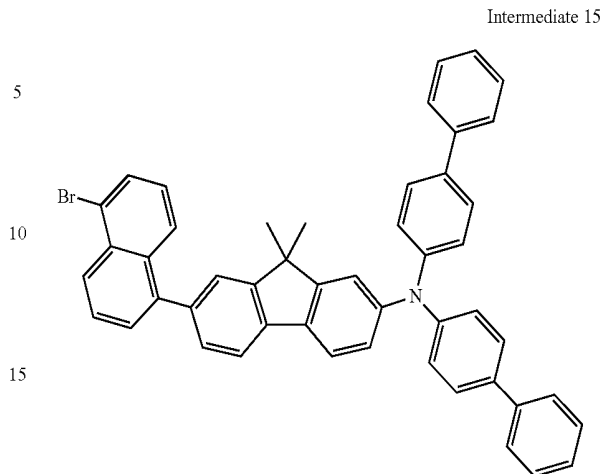

89

-continued

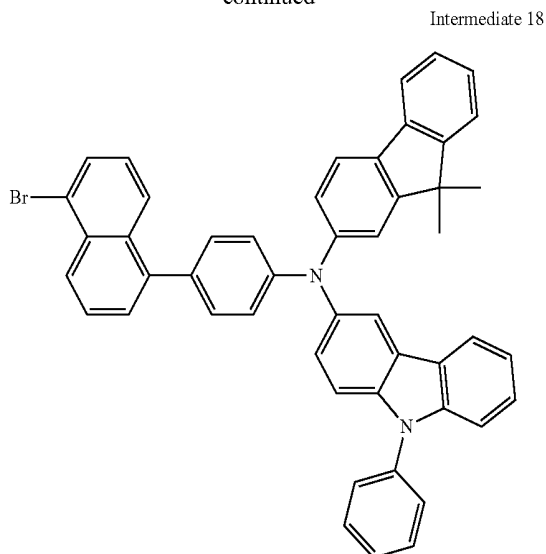

Synthesis Example 19

Synthesis of Intermediate 19

10.0 g (20 mmol) of Intermediate 12, 5.1 g (26 mmol) of benzophenone hydrazone, 42.88 g (30 mmol) of t-BuONa, 0.09 g (0.4 mmol) of Pd(OAc)<sub>2</sub>, and 0.19 g (0.4 mmol) of 2-dicyclohexylphosphino-2',4',6'-triisopropylbiphenyl were dissolved in 60 mL of toluene and stirred at 90° C. for 3 hours.

The reaction product was cooled to room temperature. Distilled water was added thereto and the product was extracted twice with 100 mL of diethylether and once with 100 mL of dichloromethane. An organic layer was collected and dried using magnesium sulfate, followed by filtration. A solvent was evaporated, and the residue was separated and purified using silica gel column chromatography to obtain 10.96 g (yield: 89%) of Intermediate 19. This compound was identified using HR-MS. C<sub>45</sub>H<sub>33</sub>N<sub>3</sub> calc.: 615.2674. found: 615.2678.

Synthesis Example 20

Synthesis of Intermediate 20

Intermediate 20 was synthesized with a yield of 92% in the same manner as Intermediate 19, except that Intermediate 13 was used instead of Intermediate 12. This compound was identified using HR-MS. C<sub>53</sub>H<sub>39</sub>N<sub>3</sub> calc.: 717.3144. found: 717.3148.

Synthesis Example 21

Synthesis of Intermediate 21

Intermediate 21 was synthesized with a yield of 90% in the same manner as Intermediate 19, except that Intermediate 14 was used instead of Intermediate 12. This compound was identified using HR-MS. C<sub>56</sub>H<sub>43</sub>N<sub>3</sub> calc.: 757.3457. found: 757.3461.

Synthesis Example 22

Synthesis of Intermediate 22

Intermediate 22 was synthesized with a yield of 88% in the same manner as Intermediate 19, except that Intermediate 15

90

was used instead of Intermediate 12. This compound was identified using HR-MS. C<sub>62</sub>H<sub>47</sub>N<sub>3</sub> calc.: 833.3770. found: 833.3774.

Synthesis Example 23

Synthesis of Intermediate 23

Intermediate 23 was synthesized with a yield of 85% in the same manner as Intermediate 19, except that Intermediate 16 was used instead of Intermediate 12. This compound was identified using HR-MS. C<sub>53</sub>H<sub>37</sub>N<sub>3</sub> calc.: 715.2987. found: 715.2991.

Synthesis Example 24

Synthesis of Intermediate 24

Intermediate 24 was synthesized with a yield of 86% in the same manner as Intermediate 19, except that Intermediate 17 was used instead of Intermediate 12. This compound was identified using HR-MS. C<sub>59</sub>H<sub>47</sub>N<sub>3</sub> calc.: 797.3770. found: 797.3774.

Synthesis Example 25

Synthesis of Intermediate 25

Intermediate 25 was synthesized with a yield of 89% in the same manner as Intermediate 19, except that Intermediate 18 was used instead of Intermediate 12. This compound was identified using HR-MS. C<sub>62</sub>H<sub>46</sub>N<sub>4</sub> calc.: 846.3722. found: 846.3726.

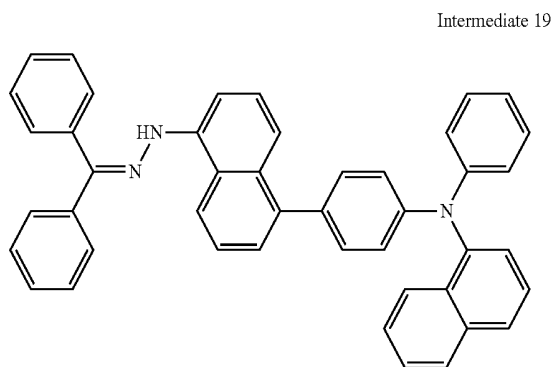

Intermediate 20

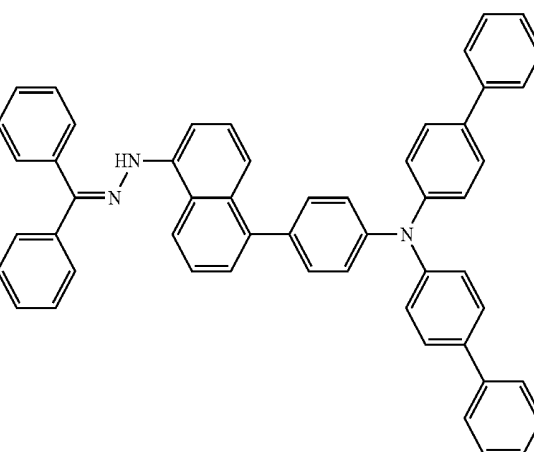

65

91

-continued

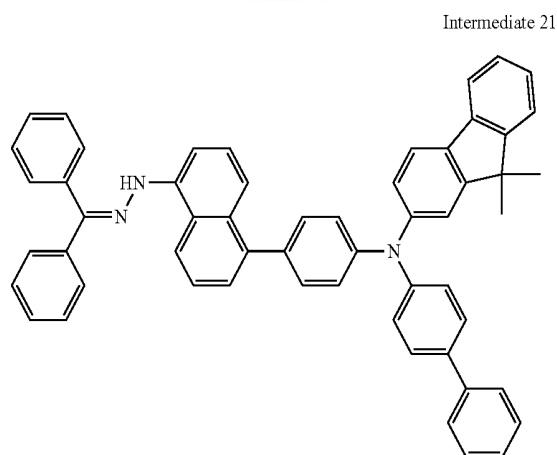
Intermediate 22
Intermediate 23
Intermediate 24

92

-continued

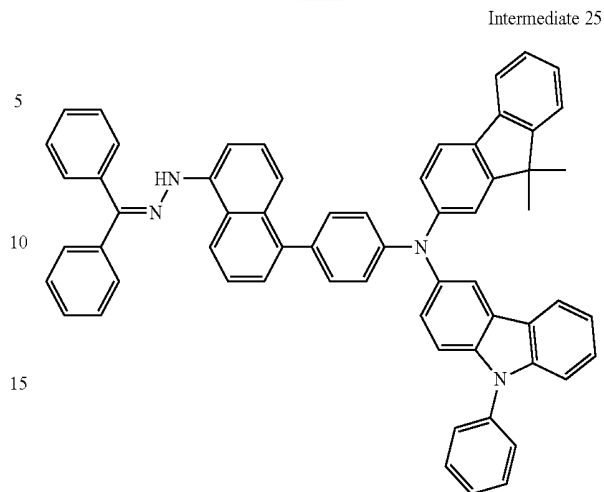

## Synthesis Example 26

## Synthesis of Intermediate 26

12.31 g (20 mmol) of Intermediate 19, 7.6 g (40 mmol) of p-toluenesulfonic acid monohydrate, and 15.70 g (80 mmol) of benzylphenylketone were dissolved in 20 mL of ethanol and 80 mL of toluene and stirred at 110° C. for 24 hours. The reaction product was cooled to room temperature. Distilled water was added thereto and the product was extracted twice with 100 mL of diethylether and twice with 100 mL of dichloromethane. An organic layer was collected and dried using magnesium sulfate, followed by filtration. The solvent was evaporated, and the residue was separated and purified using silica gel column chromatography to obtain 7.96 g (yield: 65%) of Intermediate 26. This compound was identified using HR-MS.  $C_{46}H_{32}N_2$  calc.: 612.2565. found: 612.2569.

## Synthesis Example 27

## Synthesis of Intermediate 27

Intermediate 27 was synthesized with a yield of 66% in the same manner as Intermediate 26, except that Intermediate 20 was used instead of Intermediate 19. This compound was identified using HR-MS.  $C_{54}H_{38}N_2$  calc.: 714.3035. found: 714.3039.

## Synthesis Example 28

## Synthesis of Intermediate 28

Intermediate 28 was synthesized with a yield of 66% in the same manner as Intermediate 26, except that Intermediate 21 was used instead of Intermediate 19. This compound was identified using HR-MS.  $C_{57}H_{42}N_2$  calc.: 754.3348. found: 754.3352.

93

## Synthesis Example 29

## Synthesis of Intermediate 29

Intermediate 29 was synthesized with a yield of 63% in the same manner as Intermediate 26, except that Intermediate 22 was used instead of Intermediate 19. This compound was identified using HR-MS.  $C_{63}H_{46}N_2$  calc.: 830.3661. found: 830.3665.

## Synthesis Example 30

## Synthesis of Intermediate 30

Intermediate 30 was synthesized with a yield of 68% in the same manner as Intermediate 26, except that Intermediate 23 was used instead of Intermediate 19. This compound was identified using HR-MS.  $C_{54}H_{36}N_2$  calc.: 712.2878. found: 712.2882.

## Synthesis Example 31

## Synthesis of Intermediate 31

Intermediate 31 was synthesized with a yield of 66% in the same manner as Intermediate 26, except that Intermediate 24 was used instead of Intermediate 19. This compound was identified using HR-MS.  $C_{60}H_{46}N_2$  calc.: 794.3661. found: 794.3665.

## Synthesis Example 32

## Synthesis of Intermediate 32

Intermediate 32 was synthesized with a yield of 72% in the same manner as Intermediate 26, except that Intermediate 25 was used instead of Intermediate 19. This compound was identified using HR-MS.  $C_{63}H_{45}N_3$  calc.: 843.3613. found: 843.3617.

94

-continued

Intermediate 27

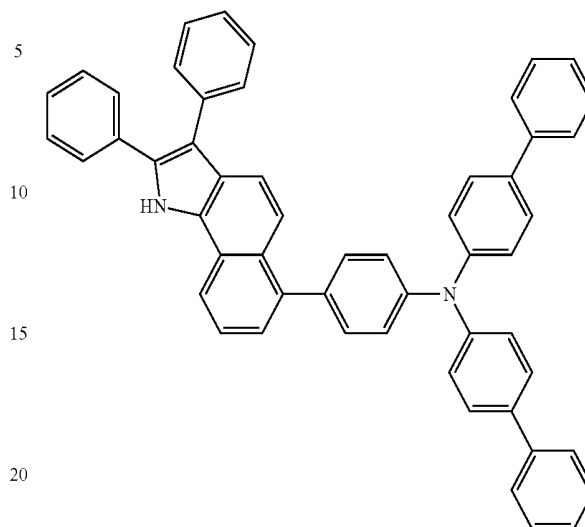

25

Intermediate 28

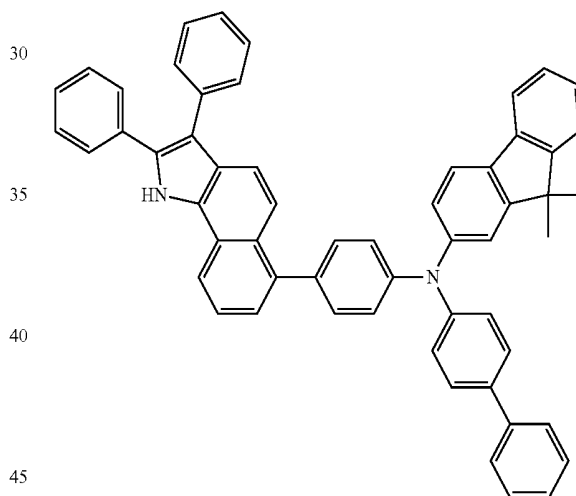

45

Intermediate 26

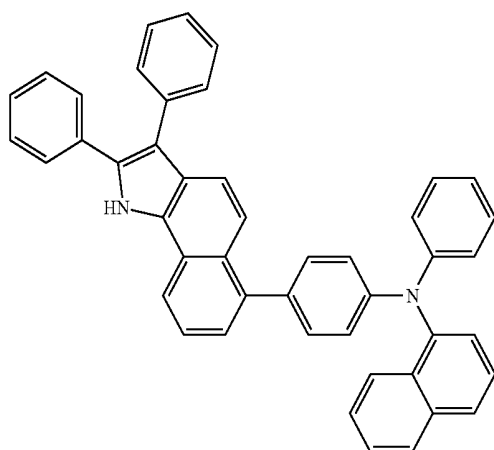

50

Intermediate 29

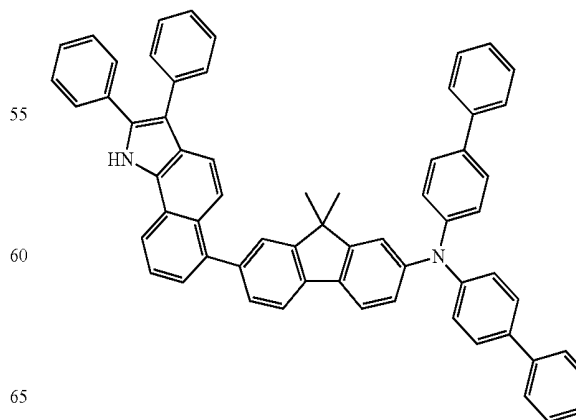

65

95

-continued

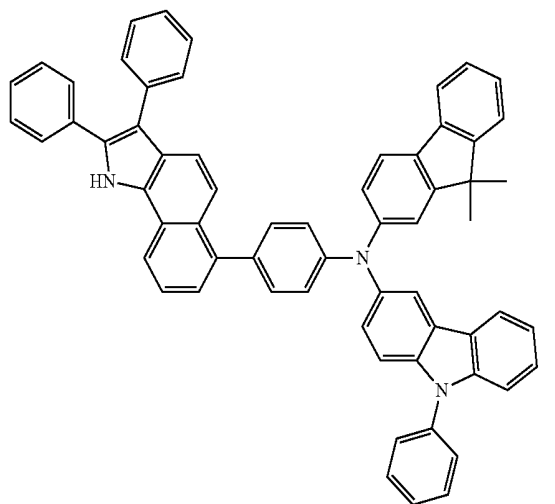
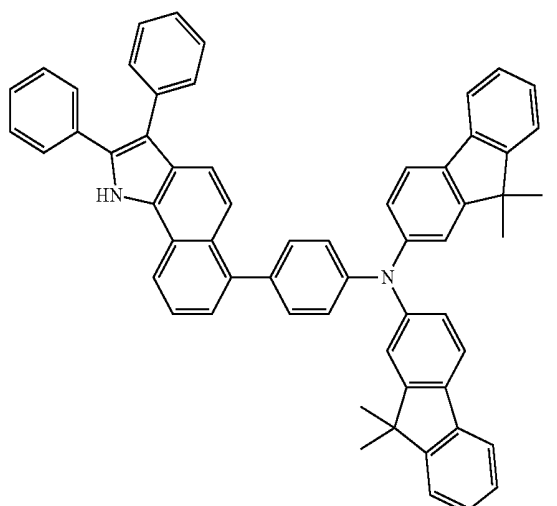
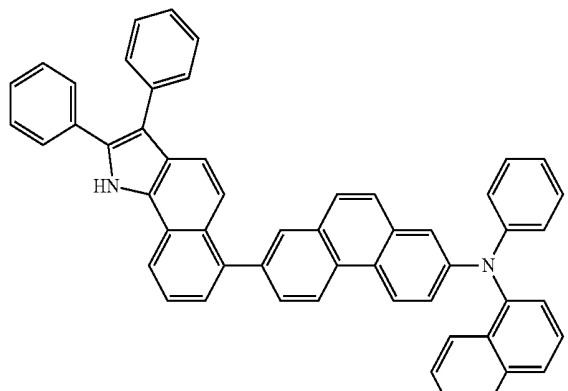

## Synthesis Example 33

## Synthesis of Compound 1

6.12 g (10 mmol) of Intermediate 26, 1.88 g (12 mmol) of bromobenzene, 2.9 g (30 mmol) of t-BuONa, 366 mg (0.4 mmol) of Pd<sub>2</sub>(dba)<sub>3</sub>, and 80 mg (0.4 mmol) of P(t-Bu)<sub>3</sub> were dissolved in 60 ml of toluene and stirred at 90° C. for 3 hours. After the reaction was completed, the reaction product was

96

cooled to room temperature and extracted three times with distilled water and 50 ml of diethylether. An organic layer was collected and dried using magnesium sulfate to evaporate the solvent. The residue was separated and purified using silica gel column chromatography to obtain 5.72 g (yield: 83%) of Compound 1. This compound was identified using HR-MS and nuclear magnetic resonance (NMR). C<sub>52</sub>H<sub>36</sub>N<sub>2</sub> calc.: 688.2878. found: 688.2882; <sup>1</sup>H NMR (CDCl<sub>3</sub>, 400 MHz) δ (ppm) 8.75 (d, 1H), 8.50 (d, 1H), 8.46 (d, 1H), 8.12 (d, 1H), 7.88 (d, 1H), 7.85 (d, 1H), 7.62-7.25 (m, 22H), 7.05 (d, 2H), 6.83 (d, 1H), 6.60 (d, 2H), 6.33 (d, 1H), 6.28 (d, 2H).

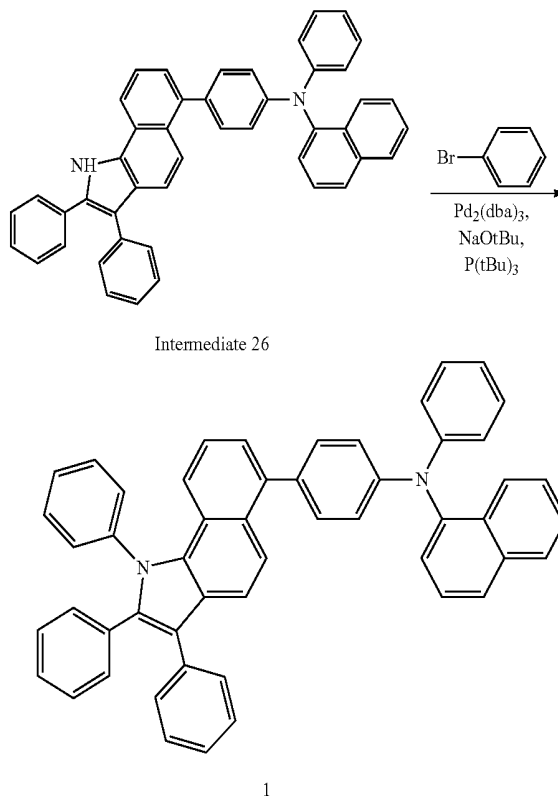

## Synthesis Example 34

## Synthesis of Compound 2

Compound 2 was synthesized with a yield of 83% in the same manner as Compound 1, except that Intermediate 27 was used instead of Intermediate 26. This compound was identified using HR-MS and NMR. C<sub>60</sub>H<sub>42</sub>N<sub>2</sub> calc.: 790.3348. found: 790.3352; <sup>1</sup>H NMR (CDCl<sub>3</sub>, 400 MHz) δ (ppm) 8.75 (d, 1H), 8.46 (d, 1H), 8.12 (d, 1H), 7.88 (d, 1H), 7.75 (d, 2H), 7.67-7.25 (d, 30H), 7.09-7.01 (m, 2H), 6.97-6.90 (d, 4H).

## Synthesis Example 35

## Synthesis of Compound 8

Compound 8 was synthesized with a yield of 81% in the same manner as Compound 2, except that 1-bromonaphthalene was used instead of bromobenzene. This compound was identified using HR-MS and NMR. C<sub>64</sub>H<sub>44</sub>N<sub>2</sub> calc.: 840.3504. found: 840.3508; <sup>1</sup>H NMR (CDCl<sub>3</sub>, 400 MHz) δ (ppm) 8.74 (d, 1H), 8.46 (d, 1H), 8.43 (d, 1H), 8.12 (d, 1H), 7.88 (d, 1H), 7.76-7.62 (m, 8H), 7.55 (t, 2H), 7.49 (d, 2H), 7.44-7.24 (m, 21H), 7.04 (t, 6H).

97

## Synthesis Example 36

## Synthesis of Compound 29

Compound 29 was synthesized with a yield of 80% in the same manner as Compound 1, except that Intermediate 28 was used instead of Intermediate 26. This compound was identified using HR-MS and NMR.  $C_{69}H_{50}N_2$  calc.: 906.3974. found: 906.3978;  $^1H$  NMR ( $CDCl_3$ , 400 MHz)  $\delta$  (ppm) 8.75 (d, 1H), 8.46 (d, 1H), 8.12 (d, 1H), 7.99 (d, 1H), 7.87 (d, 1H), 7.75 (d, 2H), 7.70-7.53 (m, 8H), 7.50 (d, 2H), 7.43-7.20 (m, 18H), 7.15 (d, 1H), 7.05 (t, 1H), 6.89 (d, 2H), 6.72 (t, 4H), 6.54 (dd, 1H), 1.92 (s, 6H).

## Synthesis Example 37

## Synthesis of Compound 32

Compound 32 was synthesized with a yield of 78% in the same manner as Compound 1, except that Intermediate 29 was used instead of Intermediate 26. This compound was identified using HR-MS and NMR.  $C_{69}H_{50}N_2$  calc.: 906.3974. found: 906.3974;  $^1H$  NMR ( $CDCl_3$ , 400 MHz)  $\delta$  (ppm) 8.77 (d, 1H), 8.44 (d, 1H), 8.11 (d, 1H), 7.76 (d, 2H), 7.71-7.24 (m, 29H), 7.15 (d, 2H), 7.11 (d, 1H), 7.08-7.01 (m, 3H), 6.85-6.82 (m, 3H), 6.74 (dd, 1H), 1.92 (s, 6H).

## Synthesis Example 38

## Synthesis of Compound 52

Compound 52 was synthesized with a yield of 79% in the same manner as Compound 1, except that Intermediate 30 was used instead of Intermediate 26. This compound was identified using HR-MS and NMR.  $C_{60}H_{40}N_2$  calc.: 788.3191. found: 788.3195;  $^1H$  NMR ( $CDCl_3$ , 400 MHz)  $\delta$  (ppm) 8.72 (d, 1H), 8.60 (d, 1H), 8.54-8.45 (m, 4H), 8.12 (d, 1H), 8.06 (s, 1H), 7.85 (d, 1H), 7.81 (d, 1H), 7.75 (d, 1H), 7.63-7.24 (m, 22H), 7.16 (d, 1H), 7.05 (d, 2H), 6.82 (t, 1H), 6.62 (d, 1H), 6.56 (d, 2H).

## Synthesis Example 39

## Synthesis of Compound 58

Compound 58 was synthesized with a yield of 78% in the same manner as Compound 1, except that Intermediate 31 was used instead of Intermediate 26. This compound was identified using HR-MS and NMR.  $C_{66}H_{50}N_2$  calc.: 870.3974. found: 870.3978;  $^1H$  NMR ( $CDCl_3$ , 400 MHz)  $\delta$  (ppm) 8.71 (d, 1H), 8.46 (d, 1H), 8.12 (d, 1H), 7.97 (d, 2H), 7.88 (d, 1H), 7.68 (d, 2H), 7.64-7.21 (m, 20H), 7.12 (d, 2H), 7.08-7.02 (m, 2H), 6.95 (t, 2H), 6.89 (d, 2H), 6.82 (dd, 2H), 1.96 (s, 12H).

## Synthesis Example 40

## Synthesis of Compound 99

Compound 99 was synthesized with a yield of 82% in the same manner as Compound 1, except that Intermediate 32 was used instead of Intermediate 26. This compound was identified using HR-MS and NMR.  $C_{69}H_{49}N_3$  calc.: 919.3926. found: 919.3930;  $^1H$  NMR ( $CDCl_3$ , 400 MHz)  $\delta$  (ppm) 8.65 (d, 1H), 8.36 (d, 1H), 8.02 (d, 1H), 7.97 (d, 1H), 7.92 (d, 1H), 7.85 (d, 1H), 7.68 (d, 1H), 7.64-7.21 (m, 29H), 7.14 (d, 1H), 7.06 (d, 2H), 6.95 (t, 1H), 6.81 (d, 2H), 6.75 (d, 1H), 1.94 (s, 6H).

98

## Example 1

An anode was prepared by cutting a Corning 15  $\Omega cm^2$  (1200 Å) ITO glass substrate to a size of 50 mm×50 mm×0.7 mm, ultrasonically cleaning the glass substrate using isopropyl alcohol and pure water for 5 minutes each, and then irradiating with UV light for 30 minutes and exposing to ozone to clean. Then, the anode was mounted in a vacuum deposition apparatus.

2-TNATA, was vacuum-deposited on the anode to a thickness of 600 Å to form an HIL, and Compound 1 as a hole transporting compound was vacuum-deposited on the HIL to a thickness of 300 Å to form a HTL.

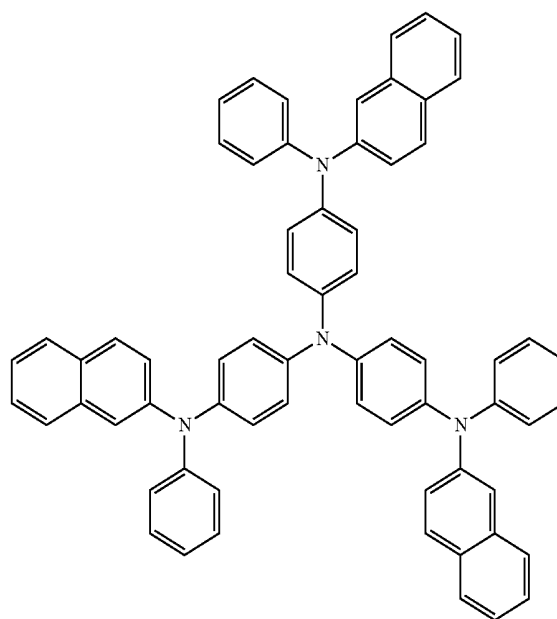

2-TNATA

Then,  $Alq_3$  as a green fluorescent host and C545T as a green fluorescent dopant were co-deposited at a weight ratio of 98:2 on the HTL to form an EML with a thickness of 300 Å.

Next,  $Alq_3$  was deposited on the EML to a thickness of 300 Å to form an ETL, and LiF was deposited to a thickness of 10 Å on the ETL to form an EIL. Finally, Al was vacuum-deposited on the EIL to a thickness of 3000 Å to form a LiF/Al electrode (cathode), thereby completing the manufacture of an organic light-emitting device.

## Example 2

An organic light-emitting device was manufactured in the same manner as Example 1, except that Compound 2 was used instead of Compound 1 to form the HTL.

## Example 3

An organic light-emitting device was manufactured in the same manner as Example 1, except that Compound 8 was used instead of Compound 1 to form the HTL.

## Example 4

An organic light-emitting device was manufactured in the same manner as Example 1, except that Compound 29 was used instead of Compound 1 to form the HTL.

99

## Example 5

An organic light-emitting device was manufactured in the same manner as Example 1, except that Compound 32 was used instead of Compound 1 to form the HTL.

## Example 6

An organic light-emitting device was manufactured in the same manner as Example 1, except that Compound 52 was used instead of Compound 1 to form the HTL.

## Example 7

An organic light-emitting device was manufactured in the same manner as Example 1, except that Compound 58 was used instead of Compound 1 to form the HTL.

## Example 8

An organic light-emitting device was manufactured in the same manner as Example 1, except that Compound 99 was used instead of Compound 1 to form the HTL.

## Comparative Example 1

An organic light-emitting device was manufactured in the same manner as Example 1, except that 4,4'-bis[N-(1-naphthyl)-N-phenylamino]biphenyl (NPB) was used instead of Compound 1 to form the HTL.

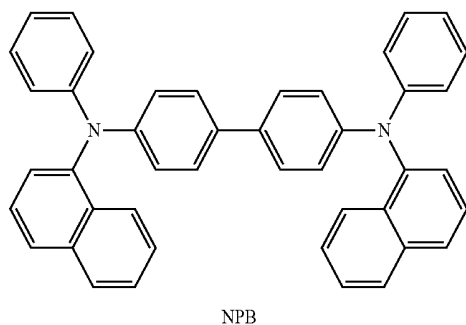

The driving voltage at a current density of 50 mA/cm<sup>2</sup>, luminance, color coordinates, and luminescent efficiency of each of the organic light-emitting devices manufactured according to Examples 1 through 6 and Comparative Example 1 were measured. The results are shown in Table 1 below.

TABLE 1

	HTL material	Driving voltage (V)	Luminance (cd/m <sup>2</sup> )	Color coordinates	Luminescent efficiency (cd/A)
Example 1	Compound 1	6.45	7980	(0.310, 0.643)	15.96
Example 2	Compound 2	6.56	7680	(0.310, 0.641)	15.36
Example 3	Compound 8	6.52	7760	(0.311, 0.641)	15.52
Example 4	Compound 29	6.43	8215	(0.309, 0.643)	16.43
Example 5	Compound 32	6.44	8196	(0.310, 0.642)	16.39
Example 6	Compound 52	6.62	7890	(0.311, 0.640)	15.78
Example 7	Compound 58	6.58	7796	(0.312, 0.642)	15.59
Example 8	Compound 99	6.67	7698	(0.310, 0.641)	15.39
Comparative Example 1	NPB	7.45	6102	(0.309, 0.642)	12.2

100

Referring to Table 1, the organic light-emitting devices manufactured using the heteroarylamine compounds of Formula 1 according to the present invention had driving voltages that were lower by 1 V or greater than when NPB was used, and thus had higher efficiency and improved I-V-L characteristics. In particular, the lifetime characteristics were markedly improved by 100% or greater in the organic light-emitting devices according to Examples 1 through 8 by 100% or greater, as compared to the organic light-emitting device according to Comparative Example 1.

The half life-span at a current density of 100 mA/cm<sup>2</sup> of each of the organic light-emitting devices manufactured according to Examples 1 through 8 and Comparative Example 1 was measured. The results are shown in Table 2 below.

TABLE 2

Example	HIL material	Half life-span (hr @ 100 mA/cm <sup>2</sup> )
Example 1	Compound 1	494 hr
Example 2	Compound 2	512 hr
Example 3	Compound 8	534 hr
Example 4	Compound 29	530 hr
Example 5	Compound 32	557 hr
Example 6	Compound 52	520 hr
Example 7	Compound 58	563 hr
Example 8	Compound 99	502 hr
Comparative Example 1	NPB	237 hr

Referring to Table 2, the organic light-emitting devices according to Examples 1 through 8 had longer half life-spans than the organic light-emitting device according to Comparative Example 1.

The heteroarylamine compounds of Formula 1 have improved electrical characteristics and charge transporting capabilities, and thus may be used as at least one of a hole injecting material, a hole transporting material, and a material for emission layers. These materials are suitable for any color fluorescent and phosphorescent devices, such as red, green, blue, and white fluorescent and phosphorescent devices.

Organic light-emitting devices including organic layers containing the heteroarylamine compound of Formula 1 have high efficiency, low driving voltages, and high luminance.

While the present invention has been illustrated and described with reference to certain exemplary embodiments, it is understood by those of ordinary skill in the art that various modifications and changes may be made to the described embodiments without departing from the spirit and scope of the present invention as defined by the following claims.

101

What is claimed is:

1. A heteroarylamine compound represented by Formula 1 below:

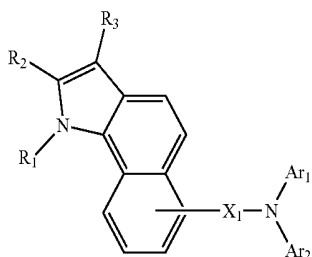

Formula 1

wherein:

each of Ar<sub>1</sub> and Ar<sub>2</sub> is independently selected from the group consisting of substituted and unsubstituted C<sub>6</sub>-C<sub>60</sub> aryl groups, substituted and unsubstituted C<sub>4</sub>-C<sub>60</sub> heteroaryl groups, and substituted and unsubstituted C<sub>6</sub>-C<sub>60</sub> condensed polycyclic groups;

X<sub>1</sub> is selected from the group consisting of substituted and unsubstituted C<sub>6</sub>-C<sub>30</sub> arylene groups, substituted and unsubstituted C<sub>4</sub>-C<sub>30</sub> heteroarylene groups, and substituted and unsubstituted C<sub>6</sub>-C<sub>30</sub> condensed polycyclic groups; and

each of R<sub>1</sub>, R<sub>2</sub> and R<sub>3</sub> is independently selected from the group consisting of hydrogen, heavy hydrogen, substituted and unsubstituted C<sub>1</sub>-C<sub>50</sub> alkyl groups, substituted and unsubstituted C<sub>1</sub>-C<sub>50</sub> alkoxy groups, substituted and unsubstituted C<sub>1</sub>-C<sub>50</sub> alkoxycarbonyl groups, substituted and unsubstituted C<sub>6</sub>-C<sub>60</sub> aryl groups, substituted and unsubstituted C<sub>5</sub>-C<sub>50</sub> aryloxy groups, substituted and unsubstituted C<sub>5</sub>-C<sub>50</sub> arylthio groups, substituted and unsubstituted C<sub>3</sub>-C<sub>50</sub> carbocyclic groups, substituted and unsubstituted C<sub>4</sub>-C<sub>60</sub> heteroaryl groups, substituted and unsubstituted C<sub>6</sub>-C<sub>60</sub> condensed polycyclic groups, halogen atoms, cyano groups, hydroxyl groups, carboxyl groups, and —N(R)(R') groups in which each of R and R' is independently selected from the group consisting of substituted and unsubstituted C<sub>1</sub>-C<sub>50</sub> alkyl groups and substituted and unsubstituted C<sub>6</sub>-C<sub>50</sub> aryl groups.

2. The heteroarylamine compound of claim 1, wherein the compound represented by Formula 1 is a compound selected from the group consisting of compounds represented by Formulae 2 through 6:

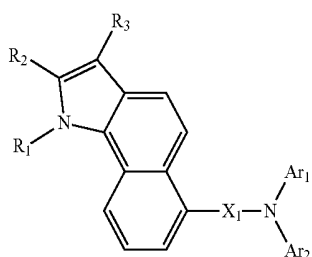

Formula 2

102

-continued

Formula 3

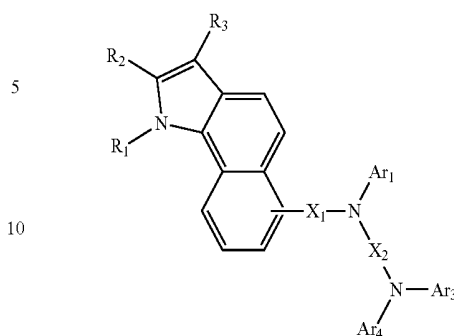

5

10

15

Formula 4

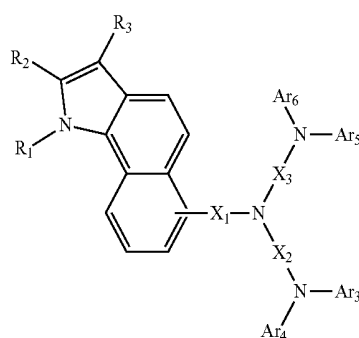

20

25

Formula 5

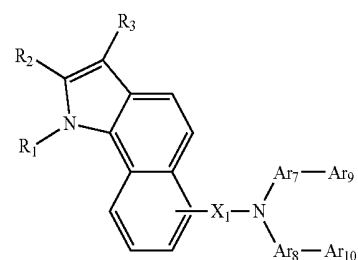

30

35

Formula 6

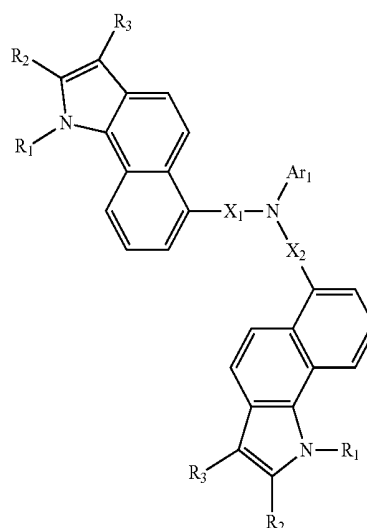

40

45

50

55

wherein:

each of Ar<sub>1</sub> through Ar<sub>6</sub>, Ar<sub>9</sub> and Ar<sub>10</sub> is independently selected from the group consisting of substituted and unsubstituted C<sub>6</sub>-C<sub>60</sub> aryl groups, substituted and unsubstituted C<sub>4</sub>-C<sub>60</sub> heteroaryl groups, and substituted and unsubstituted C<sub>6</sub>-C<sub>60</sub> condensed polycyclic groups;

each of X<sub>1</sub> through X<sub>3</sub>, Ar<sub>7</sub> and Ar<sub>8</sub> is independently selected from the group consisting of substituted and unsubstituted C<sub>6</sub>-C<sub>30</sub> arylene groups, substituted and

60

65

## 103

unsubstituted  $C_4$ - $C_{30}$  heteroarylene groups, and substituted and unsubstituted  $C_6$ - $C_{30}$  condensed polycyclic groups; and

each of  $R_1$ ,  $R_2$  and  $R_3$  is independently selected from the group consisting of hydrogen, heavy hydrogen, substituted and unsubstituted  $C_1$ - $C_{50}$  alkyl groups, substituted and unsubstituted  $C_1$ - $C_{50}$  alkoxy groups, substituted and unsubstituted  $C_1$ - $C_{50}$  alkoxycarbonyl groups, substituted and unsubstituted  $C_6$ - $C_{60}$  aryl groups, substituted and unsubstituted  $C_5$ - $C_{50}$  aryloxy groups, substituted and unsubstituted  $C_5$ - $C_{50}$  arylthio groups, substituted and unsubstituted  $C_3$ - $C_{50}$  carbocyclic groups, substituted and unsubstituted  $C_4$ - $C_{60}$  heteroaryl groups, substituted and unsubstituted  $C_6$ - $C_{60}$  condensed polycyclic groups, halogen atoms, cyano groups, hydroxyl groups, carboxyl groups, and  $-N(R)(R')$  groups in which each of  $R$  and  $R'$  is independently selected from the group consisting of substituted and unsubstituted  $C_1$ - $C_{50}$  alkyl groups and substituted and unsubstituted  $C_6$ - $C_{50}$  aryl groups.

3. The heteroarylamine compound of claim 2, wherein each of  $X_1$  through  $X_3$  is independently selected from the group consisting of phenylene groups, biphenylene groups, terphenylene groups, quarterphenylene groups, naphthylene groups, anthracenylene groups, phenanthrylene groups, chrysenylene groups, pyrenylene groups, perylenylene groups, fluorenylene groups, thiophenylene groups, 1-phenylthiophenylene groups, 1,4-diphenylthiophenylene groups, benzothiophenylene groups, 1-phenylbenzothiophenylene groups, 1,8-diphenylbenzothiophenylene groups, furylene groups, 1-phenyldibenzothiophenylene groups, 1,8-diphenyldibenzothiophenylene groups, dibenzofuranylene groups, 1-phenyldibenzofuranylene groups, 1,8-diphenyldibenzofuranylene groups, and benzothiazolylene groups.

4. The heteroarylamine compound of claim 2, wherein each of  $Ar_1$  through  $Ar_6$ ,  $Ar_9$  and  $Ar_{10}$  is independently selected from the group consisting of:

monocyclic to tricyclic aryl groups selected from the group consisting of phenyl groups, naphthyl groups, biphenyl groups, terphenyl groups, fluorenyl groups, and carbazolyl groups; and

monocyclic to tricyclic aryl groups in which an aromatic ring is substituted with one to three substituents selected from the group consisting of  $C_1$ - $C_5$  alkyl groups,  $C_1$ - $C_5$  alkoxy groups, cyano groups, amino groups, phenoxy groups, phenyl groups, and halogen atoms.

5. The heteroarylamine compound of claim 2, wherein each of  $X_1$  through  $X_3$  is independently selected from the group consisting of:

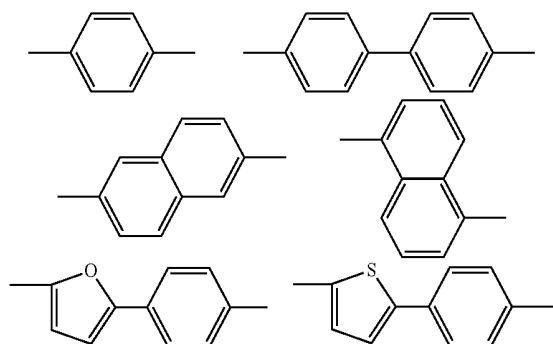

## 104

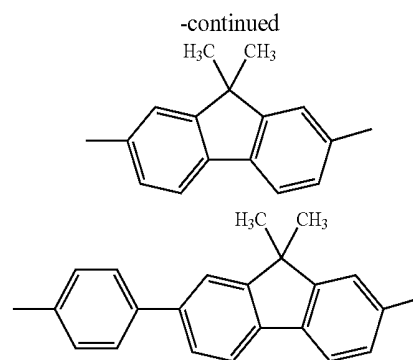

6. The heteroarylamine compound of claim 2, wherein each of  $Ar_1$  through  $Ar_6$ ,  $Ar_9$  and  $Ar_{10}$  is independently selected from the group consisting of:

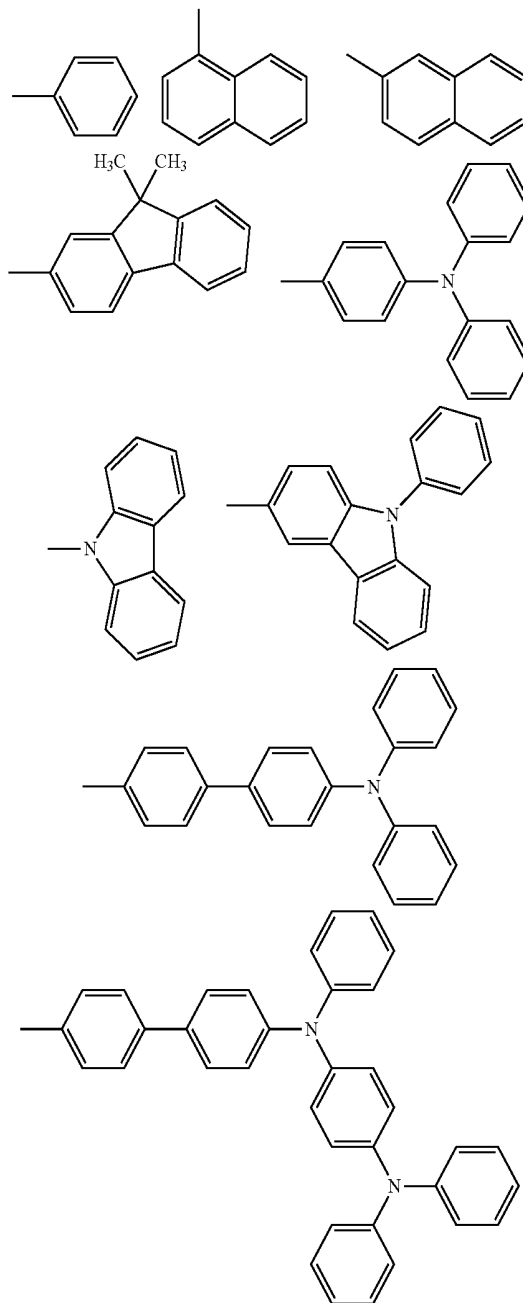

**105**  
-continued

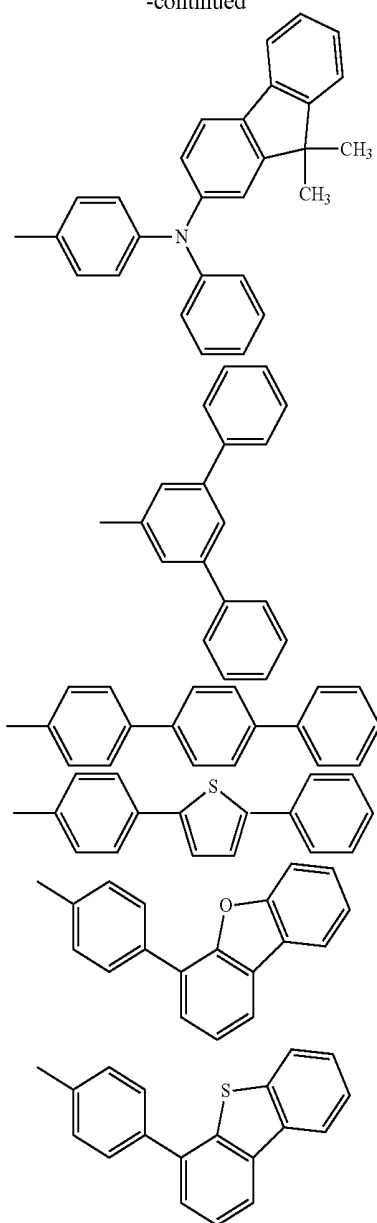

**106**  
-continued

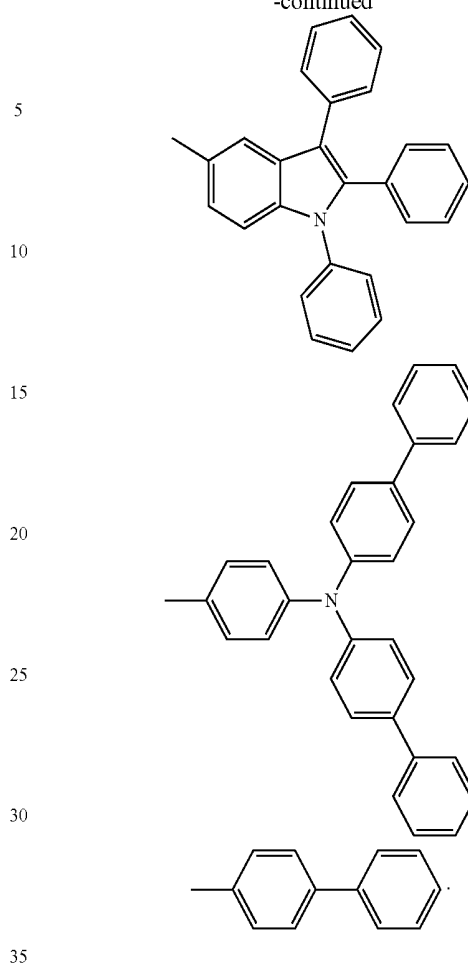

7. The heteroarylamine compound of claim 2, wherein each of R<sub>1</sub> through R<sub>3</sub> is independently selected from the group consisting of phenyl groups, 4-fluorophenyl groups, naphthyl groups, and biphenyl groups.

8. The heteroarylamine compound of claim 1, wherein the compound represented by Formula 1 is a compound selected from the group consisting of Compounds 1, 2, 8, 29, 32, 52, 58 and 99:

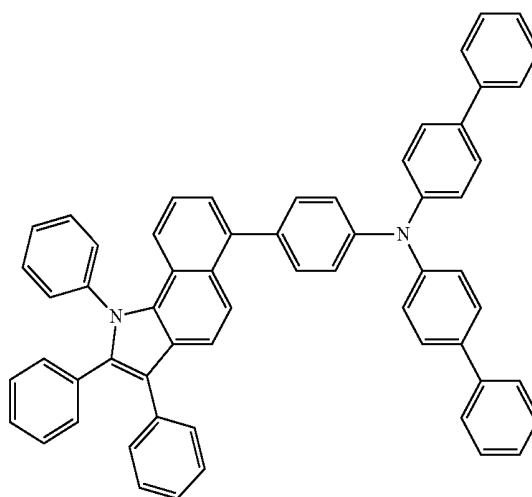
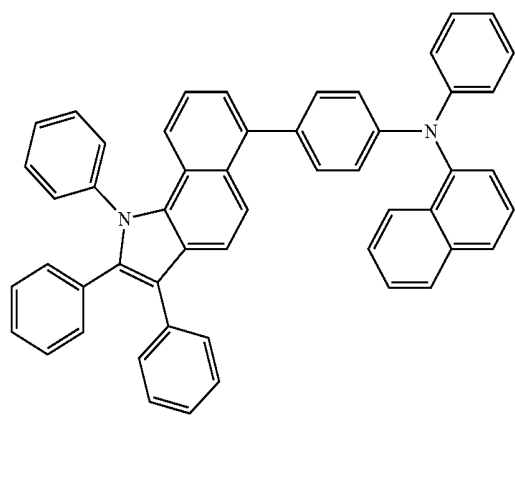

107

108

-continued  
8

29

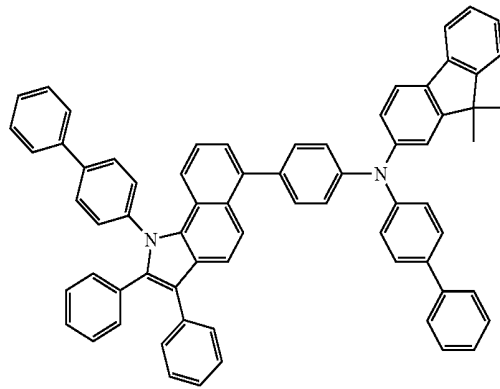
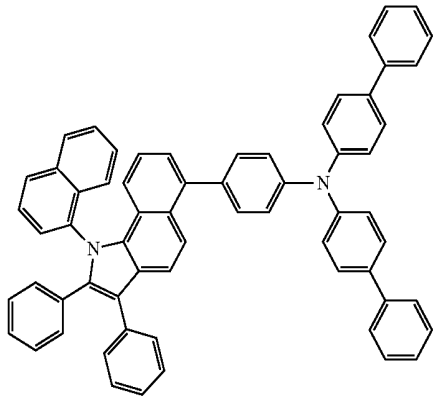

32

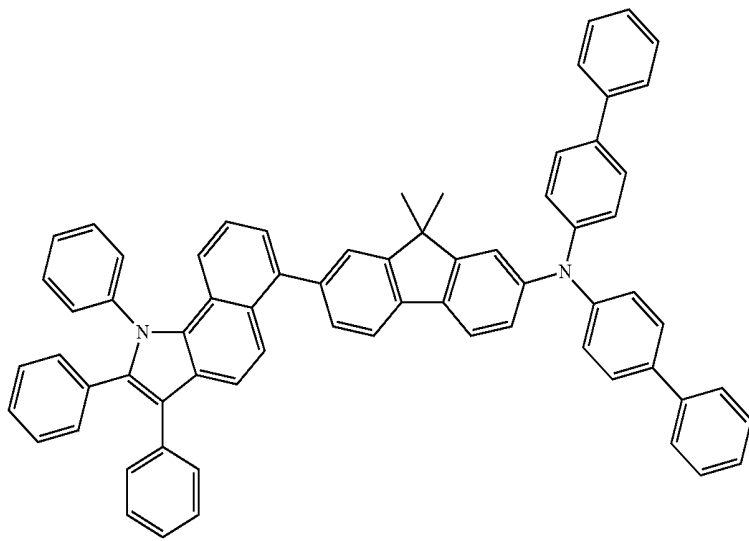

52

58

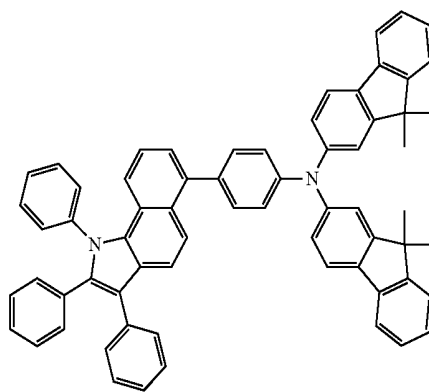
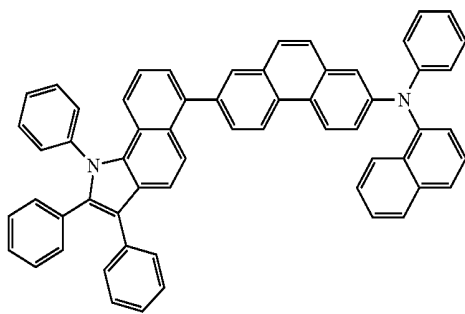

99

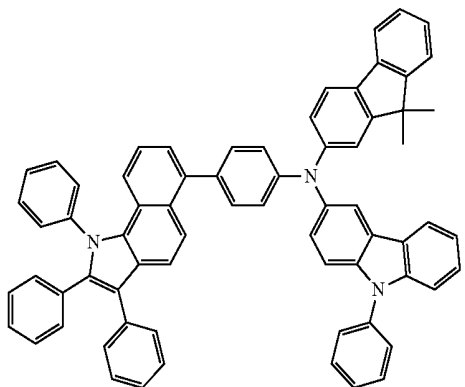

109

9. An organic light-emitting device comprising:  
a first electrode;  
a second electrode; and

an organic layer between the first electrode and the second electrode, wherein the organic layer comprises at least one layer comprising the heteroarylamine compound of claim 1.

10. The organic light-emitting device of claim 9, wherein the organic layer comprises a hole injection layer or a hole transport layer.

11. The organic light-emitting device of claim 9, wherein the organic layer comprises an emission layer or a single layer having hole injecting capability and hole transporting capability.

12. The organic light-emitting device of claim 9, wherein the organic layer comprises an emission layer comprising the heteroarylamine compound of Formula 1 as a host for a fluorescence or phosphorescence organic light emitting device.

13. The organic light-emitting device of claim 9, wherein the organic layer comprises a hole injection layer, a hole transport layer, and an emission layer, wherein the hole injection layer or the hole transport layer comprises the heteroarylamine compound of Formula 1, and the emission layer comprises an anthracene compound, a C<sub>4</sub>-C<sub>60</sub> heteroaryl compound or a styryl compound.

14. The organic light-emitting device of claim 9, wherein the organic layer comprises a hole injection layer, a hole transport layer, and an emission layer, wherein the hole injection layer or the hole transport layer comprises the heteroarylamine compound of Formula 1, and the emission layer com-

110

prises a green emission layer, a blue emission layer, a red emission layer, and a white emission layer, wherein at least one of the green emission layer, the blue emission layer, the red emission layer, and the white emission layer comprises a phosphorescent compound.

15. The organic light-emitting device of claim 9, wherein the organic layer further comprises at least one layer selected from the group consisting of a hole injection layer, a hole transport layer, an electron blocking layer, an emission layer, a hole blocking layer, an electron transport layer, and an electron injection layer.

16. The organic light-emitting device of claim 15, wherein the organic light-emitting device comprises a first electrode/hole injection layer/emission layer/second electrode structure, a first electrode/hole injection layer/hole transport layer/emission layer/electron transport layer/second electrode structure, or a first electrode/hole injection layer/hole transport layer/emission layer/electron transport layer/electron injection layer/second electrode structure.

17. A flat panel display device comprising the organic light-emitting device according to claim 9, wherein the first electrode of the organic light-emitting device is electrically connected to a source electrode or a drain electrode of a thin film transistor.

18. An organic light-emitting device comprising a first electrode, a second electrode, and an organic layer between the first electrode and the second electrode, wherein the organic layer comprises at least one layer comprising the heteroarylamine compound of claim 1, the at least one layer being formed using a wet process.

\* \* \* \* \*

专利名称(译)	杂芳胺化合物和包括其的有机发光器件		
公开(公告)号	<a href="#">US8399880</a>	公开(公告)日	2013-03-19
申请号	US12/869596	申请日	2010-08-26
[标]申请(专利权)人(译)	金荣KOOK HWANG SEOK HWAN KWAK YOON HYUN JUNG HYE JIN 李钟赫 LIM JINØ 李昌镐		
申请(专利权)人(译)	金荣KOOK HWANG SEOK-HWAN KWAK YOON-HYUN JUNG HYE-JIN 李钟赫 LIM JIN-O 李昌镐		
当前申请(专利权)人(译)	三星DISPLAY CO. , LTD.		
[标]发明人	KIM YOUNG KOOK HWANG SEOK HWAN KWAK YOON HYUN JUNG HYE JIN LEE JONG HYUK LIM JIN O LEE CHANG HO		
发明人	KIM, YOUNG-KOOK HWANG, SEOK-HWAN KWAK, YOON-HYUN JUNG, HYE-JIN LEE, JONG-HYUK LIM, JIN-O LEE, CHANG-HO		
IPC分类号	H01L51/54 C07D209/58 C07D209/88		
CPC分类号	C07D209/60 C07D209/86 C07D209/88 C07D409/14 C07D405/14 C07D409/04 C07D405/04		
优先权	1020090080703 2009-08-28 KR		
其他公开文献	US20110049494A1		
外部链接	<a href="#">Espacenet</a> <a href="#">USPTO</a>		

#### 摘要(译)

本发明的实施方案涉及由式1表示的杂芳基胺化合物，和包含该杂芳基胺化合物的有机发光装置。使用杂芳基胺化合物的有机发光器件具有高效率，低驱动电压，高亮度和长寿命。

SECOND ELECTRODE
EIL
ETL
EML
HTL
HIL
FIRST ELECTRODE